

November 2013

# EeB PPP Project Review



FP7- funded projects under the 2010, 2011 and 2012 calls

PREPARED BY



# Foreword

We are pleased to introduce the third edition of the EeB PPP Project Review.

The Energy-efficient Buildings (EeB) Public Private Partnership (PPP) is a joint initiative of the European Commission and the Energy Efficient Buildings Association (E2BA) which span out of the European Construction Technology Platform (ECTP). This initiative aims to promote research on new methods and technologies to reduce the energy footprint and CO<sub>2</sub> emissions related to new and retrofitted buildings across Europe.

This publication presents the progress of 76 funded projects\* within the EeB PPP under the FP7 Framework for 2010, 2011 and 2012. The collection of projects illustrates the diverse research needs and the importance of developing all aspects of the building sector as we strive towards our 2020 goals for energy and carbon emissions. The research projects respond to EU priorities for new technologies and systems, materials, information and communication technologies and retrofitting methodologies in order to achieve energy efficient buildings. The projects demonstrate scientific and technological excellence across all levels from early stage conception through to demonstration of the potential for commercialisation.

This edition of the EeB PPP Project Review aims to highlight the current and potential impact of the running projects. Within this portfolio, E2BA identified over 242 demonstrator projects located in 24 countries. Over 70% of demonstrators were in EU states with Spain, Italy and Germany recording the highest numbers. The total renovated area was calculated to be over 780,000m<sup>2</sup>, including district based projects. The average energy saving per project was 39% whilst the average annual carbon saving claimed per project was 4 Mt CO<sub>2</sub>. The impact of these projects is remarkable considering the €429m of private investment they attracted and the high participation of SMEs in the programme (30%).

The EeB PPP was set up under the FP7 Framework and recognises the importance of research in Europe to achieve Europe's targets of jobs creation and competitiveness, and to maintain leadership in the global knowledge economy.

As Horizon 2020 Programme starts the E2BA is looking forward to realise the vision of creating a high-tech building industry that turns energy efficiency into sustainable business. The recently completed Research and Innovation Roadmap to 2020 has established the backbone of a long term Research and Innovation programme agreed with stakeholders across Europe. In line with Horizon 2020, the EeB PPP aims to develop breakthrough affordable solutions at building and district scale, connecting to future smart cities and major European initiatives to maximise impact for the users and the Society.

We hope this Review will be interesting and informative and will provide readers with a holistic view of the work the EC and industry are funding to ensure a more efficient future for the building sector.

## **Emmanuel Forest**

President of the Energy Efficient Buildings Association (E2BA)

and **Gaëtan Desruelles**<sup>†</sup>

Former President of the Energy Efficient Buildings Association (E2BA)

\* The information on each project has been kindly provided by the project participants. Neither E2BA nor the European Commission, nor any third party can assume responsibility for any errors.

# Contents

## New nanotechnology-based high performance insulation systems for energy efficiency

- 5 AEROCOINS
- 6 COOL-Coverings
- 7 HIPIN
- 8 NANOINSULATE
- 9 NANOPCM

## Materials for new energy efficient buildings components with reduced embodied energy

- 10 BioBuild
- 11 LEEMA
- 12 SUS-CON

## New solutions for energy generation, storage and use related to space heating and domestic hot water

- 13 EINSTEIN
- 14 HEAT4U

## Technologies for ensuring, monitoring and/or controlling a high quality indoor environment in relation with energy-efficient buildings

- 15 clear-up
- 16 CETIEB
- 17 INTASENSE

## Nanotechnology based approaches to increase the performance of HVAC systems

- 18 EnE-HVAC
- 18 NANOCOOL
- 19 NANO-HVAC

## Novel materials for smart windows conceived as affordable multifunctional systems offering enhanced energy control

- 19 HarWin
- 20 MEM4WIN
- 20 SmartBlind
- 21 Winsmart

## ICT, information and communication technologies

- 22 EeBGuide
- 23 GE<sup>2</sup>O
- 24 ee-WiSE
- 24 ENBUS

## New technologies for energy efficiency and demonstration of nearly zero-energy building renovation

- 25 E-hub
- 26 FC-DISTRICT
- 27 EU-GUGLE
- 27 R2CITIES
- 28 ZenN

## Compatible solutions for improving the energy efficiency of historic buildings

- 29 3ENCULT
- 30 EFFESUS

## Demonstration of energy efficiency through retrofitting of buildings

- 31 BEEM-UP
- 32 E2ReBuild
- 33 School of the Future

### Energy saving technologies for building envelope

- 34 Cost-Effective
- 35 EASEE
- 36 MEEFS Retrofitting

### Demonstration of very low energy new buildings and systemic approach for retrofitting existing buildings

- 37 Buildsmart
- 38 DIRECTION
- 39 NEED4B
- 40 NEXT-Buildings
- 41 HERB
- 41 iNSPiRe
- 42 RetroKit

### Interaction and integration between building systems, energy storage and energy generation systems

- 42 AMBASSADOR
- 43 RESILIENT

### New 'processes and business models' for performance based energy-efficient buildings integrating new systems

- 43 NewBEE
- 44 PROFICIENT
- 44 UMBRELLA

### Building Information Modelling

- 45 HESMOS
- 46 KnoholEM
- 47 Odysseus
- 47 ORIGIN

### Sensor and Appliances Networks

- 48 SEEMPubS
- 49 TIBUCON
- 50 CASCADE
- 51 SEAM4US

### Key Performance Indicators

- 52 BEAMS
- 53 SEEDS
- 54 EPIC-HUB

### Energy Management

- 55 EnRiMa
- 56 H2SusBuild
- 57 MESSIB
- 58 SportE2
- 59 S4ECoB
- 60 COOPERaTE
- 60 E+
- 61 NRG4CAST
- 61 SmartKYE

### Smart Cities

- 62 CAMPUS21
- 63 IREEN
- 64 EEPOS
- 64 IDEAS
- 65 URB-Grade

### ICT related non-technical issues

- 66 ICT4E2B Forum
- 67 REVISITE



# AEROCOINS

## Aerogel based composite/hybrid nanomaterials for cost-effective super insulation systems in buildings

AEROCOINS proposes to create a new super-insulating material by overcoming two major obstacles which have prevented a wide-spread use of silica based aerogel super insulation components in the building envelope. These obstacles are the mechanical weakness of silica aerogels and its high cost.

### Overview

In the current context of global climate control policies, improving the energy efficiency of buildings represents great potential for energy savings. Thermal resistance of the insulation layer of the building envelope can be enhanced by significantly increasing its thickness. Another approach is decreasing the thermal conductivity of the insulation using new super-insulating components or materials.

Aerogels are light weight, nanoporous solids perfect for thermal insulation with the lowest thermal conductivity ever known in ambient conditions ( $\lambda < 0.012 \text{ W m}^{-1} \text{ K}^{-1}$ ). AEROCOINS proposes a clever combination of sol-gel science and nanotechnology that can greatly advance the design and development of novel super-insulating aerogel materials.

The main goal of AEROCOINS is to develop a new composite/hybrid aerogel material to improve the thermal insulation performance of existing buildings aiming to reduce their energy demands. The main objectives are:

- Synthesise and elaborate novel, mechanically strong and super-insulating silica aerogel-based materials via an ambient drying process
- Design and fabricate highly efficient and robust building components (based on the developed aerogel composite and/or hybrid material) for implementation in the external part of existing building envelopes
- Demonstrate significant cost reduction in the commercial production of super-insulating aerogel-like materials and associated components
- Demonstrate the thermal, structural and mechanical performance of the super-insulating component in real conditions
- To obtain a definition of the global performance of the component in different representative building typologies, taking into consideration the Service Life Cost Analysis

### Key Achievements

The main expected deliverables from the AEROCOINS project are as follows.

- Obtain a reinforced aerogel-based thermally super-insulating material: improving mechanical properties while maintaining a low thermal conductivity ( $\lambda < 0.018 \text{ Wm}^{-1} \text{K}^{-1}$ ) by polymeric cross-linking and/or nano-dispersion concepts based on the use of cellulosic species
- Develop an ambient drying process
- Design and fabricate a novel building component prototype based on the developed aerogel-like material
- Design a cost-effective continuous industrial level process for the production of the aerogel-like material boards
- Demonstrate the thermal and structural performance of the highly insulating component under real conditions



SiO<sub>2</sub> Aerogel with modified MicroFibrillated Cellulose (MFC) fibers, EMPA



### KEY FACTS

**Start date:** June 2011

**Duration:** 48 months

**Total budget (€):** 4.3 million

**Website:** [www.aerocoins.eu](http://www.aerocoins.eu)

**Coordinator:** TECNALIA, Spain

**Partners:** France: ARMINES, PCAS, SEPAREX.

Finland: VTT. Germany: ZAE BAYERN. Poland:

POLITECHNIKA LODZKA. Spain: Acciona.

Switzerland: EMPA.

### EXPECTED IMPACT

- 2 demonstrators in total (Spain)
- 30% reduction in energy use
- Over 6000 people reached by dissemination activity
- 7 people trained
- 1-2 technologies may be taken to market
- 1-2 patents may be applied for

# COOL-Coverings

## Development of a novel and cost-effective range of nanotech improved coatings

The objective of COOL-Coverings is to develop innovative nano-based materials for the building envelope with enhanced near infrared reflectance that stay cool under sun radiation reducing cooling energy demand and improving indoor comfort. Different multifunctional products for roofs and façades have been developed from roof membranes to ceramic tiles and acrylic paints.

### Overview

Today, primary energy use in the built environment accounts for about 40% of total EU energy consumption. Cooling is a major energy consumer in both commercial and residential buildings. Considering during hot summers most of the heat gain is due to sun radiation, emitted as about 50% invisible light in the Near infrared (NIR) range, a significant reduction in cooling energy demand can be obtained by improving surface reflectivity rather than adding insulating layers.

The COOL-Coverings project aims to develop a novel and cost-effective range of nanotech enabled insulation materials to improve building envelope energy efficiency in retrofitting or new constructions. The technical strategy consists of developing nano-technologies that significantly improve the NIR reflection capabilities of existing covering products for roofs and façades while keeping traditional colours.

The so called cool materials, with enhanced reflecting and emitting properties, will guarantee several benefits both for the building owners and the environment. These include reduction in cooling energy demand and energy peaks, improvement of indoor comfort and material durability and mitigation of the urban heat island phenomenon.

Overall objectives of the project are:

- Development of nano-based coloured covering materials (roof membranes, paints and ceramic tiles) with enhanced

NIR reflectance (combining thermal performances with aesthetics value)

- Integration of innovative cool technologies into traditional manufacturing processes in order to obtain cost-effective solutions for building insulation
- Development of multifunctional paint formulations (for wall and roof membranes) that offer, beside cooling capabilities, additional properties such as algae resistance, waterproofness and thermal insulation
- Development of numerical and experimental tools for cool material characterisation at lab, pilot study scale and real building levels

### Key Achievements

The main outcome of the COOL-Coverings project is an innovative range of multifunctional nano-based materials for the building envelope with improved NIR reflectance (+30%). These include ceramic tiles; acrylic paints with additional functions such as water repellence, lower thermal conductivity and improved algae resistance; bituminous membrane with improved algae resistance, waterproofness, lightness and mechanical resistance.

The consortium has extracted expertise from industrial and research partners in order to obtain a full characterisation of the aforementioned materials in all aspects ranging from risk assessment and performance evaluation (thermal properties, durability, etc.) to economical and sustainability analysis (market analysis, LCA).



### KEY FACTS

**Start date:** June 2010

**Duration:** 36 months

**Total budget (€):** 4.3 million

**Website:** [www.coolcoverings.org](http://www.coolcoverings.org)

**Coordinator:** KERABEN GRUPO, Spain

**Partners:** Finland: Finnish Institute of Occupational Health. Germany: Active Space Technologies, Borner. Greece: NANOPHOS, National Technical University of Athens. Italy: CSGI, D'Appolonia, MBN Nanomaterialia, Università Politecnica delle Marche. Netherlands: TNO. Poland: Mostostal. Spain: Instituto de Tecnología Cerámica. Switzerland: IRIS SW.

### EXPECTED IMPACT

- 5 demonstrators in total (Spain)
- Estimated 60m<sup>2</sup> of cool materials applied in the demonstration park
- 10-50,000 people reached by dissemination activity
- Less than 5 year payback on investment
- €1.3 million investment from project partners
- Key training actions: Preparation of educational materials for universities, publishing of articles and preparation of guidelines for material applications
- 500-1,000 people trained
- 36% of project partners are SMEs
- Estimated 10 technologies may be taken to market



Demonstration park located in Algete (Madrid), an experimental platform designed to test innovative materials under controlled conditions

# HIPIN

## High performance insulation based on nanostructured encapsulation of air

High Performance Insulation Based on Nanostructured Encapsulation of Air (HIPIN) is developing a sustainable, cost-effective route to a nanostructured aerogel-based coating to improve the thermal efficiency of buildings, thereby having a significant impact on the reduction of greenhouse gases. The innovative multi-functional (self-cleaning, fire retardant) aerogel developed within this project will be incorporated into paint, plaster and panels for building applications.

### Overview

Increasing thermal efficiency targets in buildings are being achieved by thicker external walls, resulting in a lower number of homes being built on a site. For retrofit, the application of thick insulation to the inside of walls is often unwelcome because it impacts on the internal floor area. Therefore, the need for novel nano-based materials to supply future required levels of thermal performance without excessive volume and weight is acknowledged.

Aerogels have exceptional thermal performance, with thermal conductivities in the range 0.004-0.03 W/mK, compared with conventional construction materials such as concrete (0.2-1.0 W/mK). The excellent performance of aerogels is due to their highly porous (often over 95%) silica skeleton. Until recently, aerogels have been considered too expensive and mechanically fragile to make their widespread use in the construction sector possible. In fact, much of their cost has arisen from their fragility, and the expensive processing required in toughening them to survive the manufacturing process.

HIPIN uses expertise within the consortium to:

- Develop more resilient aerogels which are suitable for incorporation into insulation systems without damage. The resultant product will be at least ten times more effective than current

insulating materials used in the construction market with a target cost reduction of at least 30%.

- Develop approaches that allow aerogels to be incorporated into a suitable vehicle that can be applied as thick paint layers, thicker coatings such as plaster, or as ventilated façade panel membranes. Application to external or internal surfaces of new build or retrofit buildings will be straightforward.

### Key Achievements

At the laboratory scale, a new HIPIN precursor has been developed with high silica content to make a robust aerogel. Production of aerogels has been successfully demonstrated with the HIPIN precursor. The project has also evaluated the feasibility of incorporating aerogels into paints, plaster and panel systems. We have now established an aerogel variant that is more suitable for each system. Future work will optimise the above aerogel and enhance its multifunctional properties thus demonstrating the insulation performance of the final product.



### KEY FACTS

**Start date:** November 2011  
**Duration:** 36 months  
**Total budget (€):** 2.9 million  
**Website:** www.hipin.eu  
**Coordinator:** TWI, UK  
**Partners:** Italy: Envipark, Methodo, Vimark.  
Sweden: Airglass. Turkey: Orient Research. UK: ICI, Thomas Swan.

### EXPECTED IMPACT

- 6 demonstrators in total (Italy)
- 500-1000 people reached by dissemination activity
- Key training actions: Training and technical transfer within the consortium
- 10 people trained
- 60% of project partners are SMEs
- 4 technologies may be taken to market
- 2 patents may be applied for

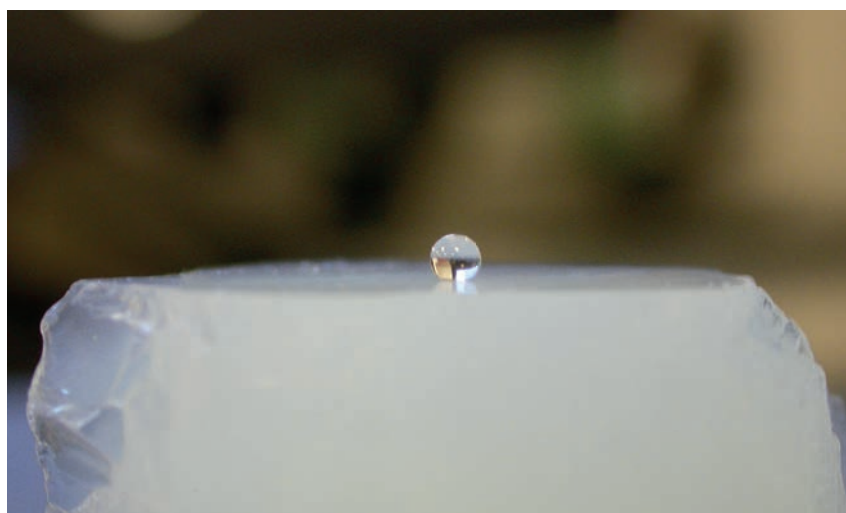

Hydrophobic aerogel

# NANOINSULATE

## Development of nanotechnology-based insulation systems

NanoInsulate develops durable, robust, cost-effective, opaque and transparent vacuum insulation panels (VIPs). VIPs will incorporate new nanotechnology based core materials such as nanofoams, aerogel composites and high-barrier films. This will result in panels up to six times more energy efficient than currently available solutions. These new systems will provide a product lifespan of over 50 years for new and existing buildings.

### Overview

The application of nanotechnology based thermal insulation systems and materials is gaining popularity within the EU construction sector which has largely been driven by environmental concerns. It has been reported that significant heat losses through inadequate or poorly performing building insulation systems is responsible for 40% of total energy consumption and approximately 36% of CO<sub>2</sub> emissions in the EU. Therefore, reducing the energy consumption by improving the performance of thermal insulation systems during the whole life-cycle of the building is an effective method against climate change. In addition, it contributes towards the reduction of the EU's energy import dependence.

Systems based on nanostructured materials potentially offer far superior thermal and mechanical properties than modern insulation systems. Inorganic silica aerogels and organic nanoporous materials are characterised by very low thermal conductivities, i.e. 0.005-0.015 W/m.K. The barriers to rapid wide-scale commercialisation lie in integrating these materials with added functionality into products suitable for use in buildings using low cost or high volume sustainable processes.

Technological concepts developed by one of the consortium partners indicate

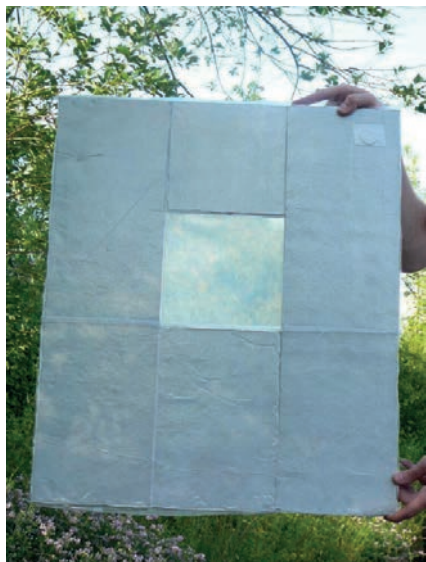

Monolithic Aerogel Slab incorporated into an opaque VIP panel. Photograph by va-Q-tec

these nanostructured materials can be enveloped in high barrier films to produce vacuum insulation panel (VIP) systems. Preliminary experimental studies have shown that these thin and lightweight nano based vacuum insulation systems are 6 times more energy efficient than commercial counterparts. The project aims to develop the necessary materials (aerogels, nanofoams and high barrier films), models, life cycle analysis, demonstration and pilot process technologies for the development of robust and efficient VIPs.

### Key Achievements

- Transparent aerogel VIPs are produced with a thermal conductivity of 9 mW/(mK)
- Transparent and crack resistant large-scale aerogel panels mechanically strengthened with polymeric silanes by chemical vapour deposition, can be obtained
- Lowest thermal conductivity measured for advanced foam based VIPs is 3.6 mW/mK
- Transparent and opaque high barrier films with gas and water vapor transmission rates of 10<sup>-3</sup> cm<sup>3</sup>/(m<sup>2</sup>d bar) and g/m<sup>2</sup>d are produced
- VIP fragility is reduced by integration into constructive elements (encapsulation in PIR foam, EPS, fiberglass), thereby improving their applicability in buildings
- Demonstration activities have started at Madrid and Warsaw



### KEY FACTS

**Start date:** July 2010

**Duration:** 48 months

**Total budget (€):** 6 million

**Website:** [www.nanoinsulate.eu](http://www.nanoinsulate.eu)

**Coordinator:** KINGSPAN, Ireland

**Partners:** Germany: BASF, Fraunhofer, va-Q-tec. Israel: Hanita. Spain: Acciona, Gaiker. Sweden: Airglass. Turkey: Koç University. UK: Pera.

### EXPECTED IMPACT

- 2 demonstrators in total (Madrid and Warsaw)
- Several hundred people reached by dissemination activity
- 33% of project partners are SMEs

# NANOPCM

## New advanced insulation phase change materials

The aim of the project was the development, implementation, production and demonstration of low cost insulation materials able to store heat by the incorporation of Phase Change Materials (PCM) and nanotechnology. These materials will be used in existing and new buildings for the reduction of energy consumption, and carbon emissions while also using by-products of different industries.

### Overview

The increasing problem of climate change has focussed efforts for the reduction of carbon emissions and its equivalent energy savings. European carbon emissions in 2007 were 4 Gton with around 23% of this due to building space heating. Materials developed in this project will reduce carbon emissions proportionally to energy savings. The 42% reduction in energy wastage achieved by current insulation measures can be improved through the use of NanoPCM products by at least 20%. NanoPCM products can also decrease CO<sub>2</sub> emissions by 600 Mt in combustion gases.

During the project, an in depth study covering the optimisation of PCM use together with nanotechnology was carried out. Results highlighted best practices for manufacturing materials able to improve traditional matrices in terms of thermal storage. Finally, the NanoPCM products were industrially produced to be installed in two different locations, Warsaw and Madrid. The main advantage of using these products is that they can be adapted to different matrices and climates without losing their thermal

storage capacity. Because of this, the NanoPCM products can be used in materials already used for insulation or commonly installed in every type of building.

The expected impact of the project is to cover the needed refurbishment of 20% of European buildings and to use the NanoPCM products as insulation materials in new construction in Europe.

### Key Achievements

- Optimisation of PCMs and methodology to insert the PCMs in traditional matrices
- Scale-up of microencapsulated PCM production and knowledge. Currently, the pilot plant is working at 8.5 Kg/h of product
- Safety and risk issues have been covered by the project. Life Cycle Assessment guidelines have demonstrated greater performance of NanoPCM products in comparison to traditional insulation materials
- Exploitation and dissemination activities have made the first tests possible using commercial products through collaboration with industrial companies



### KEY FACTS

**Start date:** June 2010  
**Duration:** 36 months  
**Total budget (€):** 3.5 million  
**Website:** [www.nanopcm-eu.net](http://www.nanopcm-eu.net)  
**Coordinator:** Acciona, Spain  
**Partners:** Germany: Active Space Technologies GmbH. Italy: Diad Group SRL. Lithuania: Housing and Urban Development Agency. Poland: Purinova Sp zoo. Spain: IK4 Tekniker, University of Castilla La Mancha. UK: PCM Products.

### EXPECTED IMPACT

- 2 demonstrators in total (Poland and Spain)
- 20% reduction in energy use and 33Mt CO<sub>2</sub> savings per year
- 60m<sup>2</sup> surface area insulated with NanoPCM products during the project
- 1 dwelling involved
- More than 1000 people reached by dissemination activity
- Estimated 100% return on investment
- €1.1 million investment from project partners
- Key training actions: Training in Universities (UCLM), knowledge about the pilot plant operation, one PhD developed during the project
- More than 15 people trained
- 50% of project partners are SMEs
- 4 technologies may be taken to market
- 2 patents may be applied for



Production plant of NANOPCM additive developed during the project

# BioBuild

## High-performance, economical and sustainable biocomposite building materials

The aim of BioBuild is to use biocomposite materials to reduce embodied energy in building façades and internal partition systems by at least 50% compared to current materials, with no loss of performance or increase in cost.

### Overview

Biocomposites generally have lower embodied energy than conventional construction materials because they are based on natural fibres and resins derived from biological material. The stiffness-to-weight ratio of such composites can be similar to glass-fibre-reinforced polymers (GRP), making them useful materials for a range of construction applications.

Biocomposites are not widely used in construction applications because the materials are prone to degradation by moisture and do not perform as well in fire tests as more conventional building materials. The project will develop biocomposites capable of offering 40 years outdoor durability by protecting the fibres using treatments and coatings. Treatments will also be applied to the fibres or the composite to improve the reaction to fire. Cork and biobased foams will be used to improve the thermal and acoustic-insulating performance of the materials, coupled with system design. Panels will be made by infusion, vacuum bagging or compression moulding, with pultruded biocomposite profiles to increase stiffness and functionality.

The result of the project will be low cost, lightweight, durable and sustainable biocomposite building systems, based on panels, profiles, frames and sandwich

structures, with full technical and environmental validation. Case-study components of these systems will be manufactured at full-scale. Case studies will encompass an external wall panel, a cladding system, an internal partition kit and a suspended ceiling. These case studies will be integrated into a single room-sized demonstrator. A full life-cycle analysis will be completed to evaluate the environmental impact of the project. An additional objective is to produce a guide for designing with biocomposites, providing best-practice advice to designers.

### Key Achievements

BioBuild partners have been collaborating to analyse international standards, distilling them into overall specifications to satisfy a broad range of applications, which will, after testing, facilitate early adoption by end-users. Small-scale methods of manufacturing composites using the new resins have been proven, using our understanding of rheology, reaction mechanisms and kinetics of cure. A number of case-study designs and materials have been planned in detail. In addition, several fibre treatments have been carried out by partners. These are being evaluated in combination with bio-resins and manufacturing methods.



### KEY FACTS

**Start date:** December 2011  
**Duration:** 42 months  
**Total budget (€):** 7.7 million  
**Website:** [www.biobuildproject.eu](http://www.biobuildproject.eu)  
**Coordinator:** NetComposites, UK  
**Partners:** Belgium: KU Leuven, TransFurans Chemicals. Denmark: 3XN. Germany: Arup, Fiber-Tech, IVW. Netherlands: SHR, TNO. Portugal: Amorim Cork Composites, LNEC. UK: Exel Composites.

### EXPECTED IMPACT

- 1 demonstrator, showing the 5 case-study parts, which will then be assembled at different locations
- Over 200 people reached by dissemination activity and 15,000 people made aware of the project via the Net-Composites newsletter
- Key training actions: Workshops will be used to inform industry later in the project
- 31% of project partners are SMEs
- 5-6 technologies may be taken to market
- 2-3 patents may be applied for

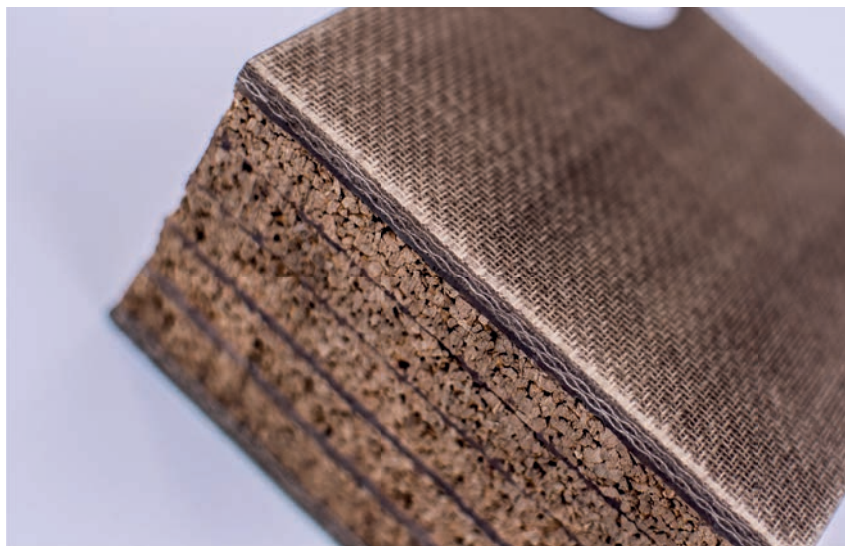

A biocomposite sandwich material with a cork core and skins of jute-furan. This material is intended for use as an interior partition in a building © GXN

# LEEMA

## Low embodied energy, advanced materials and insulating masonry components for energy efficient buildings

LEEMA aims to develop a new generation of inorganic insulation materials and building insulation masonry components with 50% less embodied energy and a reduction in the total cost of 15% compared to current insulation materials and products.

### Overview

In recent years the concept of energy use in buildings (heating, lighting, etc) and the need to reduce it has become increasingly familiar. However, the energy needed to create the building itself is often overlooked. An average household contains approximately 1,000GJ of embodied energy in the materials used for its construction; which is equivalent to about 15 years of operational energy consumption. Therefore, the use of construction materials with low embodied energy will directly improve the sustainability of buildings. The development and use of these materials should align with efforts to improve the thermal and acoustic performance of the whole building envelope. Moreover, the cost element should also be taken into account.

Within the LEEMA project a range of new insulation products will be developed suitable for both new and retrofitted buildings to include loose filling insulation materials, innovative Fesco-, foam- and fibre- boards and innovative bricks with advanced insulation properties. The production of these insulation materials will be based on intelligent use of inert, “zero-embodied energy” wastes originating from industrial mineral exploitation (i.e. perlite, bentonite, amorphous silica and other volcanic minerals) and other industrial wastes.

Very low energy consuming processes, based on inorganic polymerisation and thermal expansion, will be investigated. Chemical compositions of the designed formulations will enable the synthesis of the new insulation materials at significantly milder conditions.

The environmental sustainability of each one of the new insulation components, as well as their compliance with technical, safety, health and environmental performance, will be assessed according to all relevant European standards.

### Key Achievements

Formulations regarding all innovative insulation components have been developed at lab scale. The challenge was to design formulations with characteristics appropriate for the production of the final insulation components under different techniques and with varied final physicochemical properties.

Innovative processes of inorganic polymerisation and thermal expansion at lower temperatures have been successfully implemented. The positive results up to now are derived from fruitful collaboration with the research and industrial partners.



### KEY FACTS

**Start date:** January 2012

**Duration:** 48 months

**Total budget (€):** 8.1 million

**Coordinator:** S&B Industrial Minerals S.A., Greece

**Partners:** Belgium: CAE Services GEIE, Centre Scientifique et Technique de la Construction, REDCO NV. Czech Republic: FENIX TNT SRO. France: Thermal Ceramics de France S.A.S. Germany: Bauhaus-Universität Weimar, KG, Schlagmann Baustoffwerke GmbH & Co, Universität Stuttgart. Greece: FIBRAN, National Technical University of Athens, Proigmenes Erevnitikes & Diaheiristikos Efarmoges. Italy: D'Appolonia Spa, Morando S.r.l.

### EXPECTED IMPACT

- Estimated 1000–1500 people reached by dissemination activity
- Key training actions: 1 publication in Innovation Energy magazine, first questionnaire distributed in various European construction sectors, video under production
- 15% of project partners are SMEs
- 3 technologies may be taken to market
- 1-5 patents may be applied for



Clay bricks with advanced insulation properties

# SUS-CON

## Sustainable, innovative and energy efficient concrete, based on the integration of all-waste materials

The project aims to integrate waste materials into the production cycle of concrete for both ready-mixed and pre-cast applications. This will result in an innovative light-weight, eco-compatible and cost-effective construction material, made using all waste raw materials and characterised by enhanced thermal insulation performance and a low embodied energy and CO<sub>2</sub> footprint.

### Overview

The concrete industry plays a predominant role in the construction sector's environmental impact. Mostly responsible for energy consumption and CO<sub>2</sub> emissions is the binder, while the aggregates have the highest impact on the concrete's thermal resistance which heavily affects the energy consumption of the buildings when in service. Preliminary tests demonstrated the possibility of reducing the embodied energy and CO<sub>2</sub> footprint of concrete through total replacement of current binders by novel ones (geo-polymers) made of waste or by-products in addition to producing thermally efficient and light aggregates, composed completely of waste.

This framework led to the SUS-CON project which aims to boost and link the dual research lines (binders and aggregates), allowing for the development of an innovative lightweight all-waste concrete.

The main goal of the project is to develop novel technologies to integrate waste into the production cycle of lightweight concrete, acting on both the main concrete components in order to produce an all-waste and energy efficient material for both ready mixed and precast applications. The focus will be on waste materials that currently cause huge socio-economic problems and which are available in quantities large enough to

feed the concrete industry. This will lead to improved sustainability and cost-efficiency in the concrete industry, as well as reducing the environmental and social impact of waste.

The project's goal will be achieved through a number of intermediate objectives including an EU overview of the candidate waste materials and processes to produce lightweight aggregates from solid wastes. In addition the project seeks to completely replace Portland cement with waste binders and produce lightweight aggregates from solid wastes. Specific mix-design methodology and working procedures, pilot plants, decision-support tools and application guidelines will also help to achieve the goal.

### Key Achievements

To date, the project has achieved an initial EU overview of the candidate waste materials, organised in a geographical database. Several challenges were faced, such as the unavailability of some of the collected data at the desired level of structuring.

The complex normative framework was also clarified and important scientific findings achieved relating to the use of different waste materials as concrete aggregates. A suitable geo-polymeric matrix has also been obtained although the low effectiveness of waste alkali activators is revealing to be challenging.



### KEY FACTS

**Start date:** January 2012  
**Duration:** 48 months  
**Total budget (€):** 7.1 million  
**Website:** [www.sus-con.eu](http://www.sus-con.eu)  
**Coordinator:** Cetma, Italy  
**Partners:** Germany: BASF, Fraunhofer IBP. Greece: National Technical University Of Athens, S&B Minerals. Italy: Centro Riciclo Vedelago, Magnetti Building, TUV Italia. Netherlands: TNO. Portugal: CeNTI. Romania: Iridex Group - Plastic. Spain: Acciona. Taiwan: National Taiwan University of Science and Technology. Turkey: Iston. UK: Queen's University of Belfast.

### EXPECTED IMPACT

- 7 demonstrators in total (Italy, Romania, Greece, Turkey and Spain)
- Estimated 70% reduction in the embodied energy of concrete and 80% reduction in CO<sub>2</sub> emissions due to production
- Estimated 2 dwellings involved and 2 end users engaged
- Estimated 8000 people reached by dissemination activity
- Estimated 47% return on investment
- €2.6 million investment from project partners
- Key training actions: Workshops and demonstration sessions
- Estimated 50 people trained
- 12.5% of project partners are SMEs
- 18 technologies may be taken to market



SUS-CON specimens

# EINSTEIN

## Effective integration of seasonal thermal energy storage systems in existing buildings

The aim of EINSTEIN is to develop, evaluate and demonstrate a low energy heating system based on renewable energy and high efficiency generation technologies for existing buildings. The project focuses on Seasonal Thermal Energy Storage combined with heat pumps. This system is expected to obtain primary energy savings of up to 70% when compared with conventional systems.

### Overview

To fulfil recent EU directives, the implementation of solutions for reducing primary energy consumption is required. As current energy use in buildings accounts for approximately 40% of EU energy consumption it is essential that the existing building stock becomes the main target.

Unlike new builds, existing buildings require development and the adaptation of existing technologies due to their specific requirements and constraints. EINSTEIN is focused on reducing energy consumption in these existing buildings. Today's consumption is mainly represented by space heating and domestic hot water. Therefore solar thermal energy seems to be one of the most promising heat sources with seasonal storage being the best way to get high solar fraction values.

Within the project's framework, the overall objective will be to develop, evaluate and demonstrate a low energy heating system for existing buildings based on renewable energy and high efficiency generation technologies. In particular, the project will focus on Seasonal Thermal Energy Storage (STES) combined with heat pumps.

In order to achieve EINSTEIN's objectives:

- A novel heat pump is being developed, suitable for existing buildings and optimised to work with both STES

applications and non-seasonal water storage tanks

- STES systems and heat pumps are being adapted for existing buildings and integrated with the built environment
- A cost effective energy intervention framework for building retrofitting is being defined, considering state of the art and new technologies developed in the project
- The results are being included in a Decision Support Tool particularly useful for stakeholders
- Two pilot plants are being built to validate the suitability of the developments for improving energy savings in buildings and districts

### Key Achievements

The main results of EINSTEIN are listed below:

- Baseline for STES systems application in existing buildings has been defined. Classification of EU building stock according to energy demand requirements has been developed and HVAC and DHW systems in existing buildings has been analysed. Market potential and physical feasibility of STES systems in existing buildings has been concluded.
- State-of-the-art analysis about STES for retrofitting applications has been carried out, as well as a study on technical requirements for different storage concepts for retrofit applications.



### KEY FACTS

**Start date:** January 2012

**Duration:** 48 months

**Total budget (€):** 9 million

**Website:** [www.einstein-project.eu](http://www.einstein-project.eu)

**Coordinator:** Tecnalia, Spain

**Partners:** Bulgaria: Architectural Spies. Germany: Solites. Italy: D'Appolonia, Icoop. Netherlands: TNO. Poland: Cim-mes, MAE, Mostostal. Spain: Acciona, Airlan, Arteaga Foundation, Fomento San Sebastian, Girotze. Sweden: Scandinavian Homes. UK: University of Ulster.

### EXPECTED IMPACT

- 2 demonstrators in total (Spain and Poland)
- 70% reduction in energy use
- Estimated 1,700m<sup>2</sup> surface area renovated
- 3 dwellings involved
- Estimated €1 million investment from project partners
- 35% of project partners are SMEs

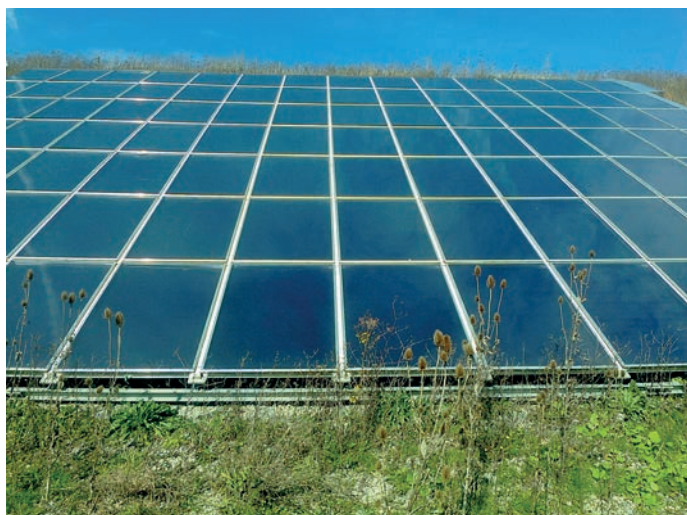

Solar thermal energy capture

# HEAT4U

## Gas absorption heat pump solution for existing residential building

HEAT4U's main concept is to develop Gas Absorption Heat Pump (GAHP) technology, enabling its cost-effective application in existing residential buildings. The technology identified in the GAHP by the proposers can effectively contribute to the European demand for the reduction of energy consumption and environmental impact in existing residential buildings.

### Overview

Residential buildings represent 60% of the building stock. They are also the area with the highest potential to drastically reduce energy use and CO<sub>2</sub> emissions. New directives push for deep retrofitting efforts, in order to achieve energy efficiency and RES adoption targets for 2020 and beyond. These require acting on both envelope and energy use systems, including heating and Domestic Hot Water (DHW) equipment which represents 51% of energy use in the sector.

Frequently, the upgrade of envelope insulation is subject to constraints (i.e. historical centres, availability of space, need to relocate tenants, costs and time issues) therefore acting on the heating plant is the only viable option. Current solutions are not always suitable or cost effective in existing buildings. To accelerate improvements in energy efficiency and the use of renewable energy in residential buildings, a specifically designed solution needs to be made available.

HEAT4U is an industry led project whose main objective is to develop a Gas Absorption Heat Pump (GAHP) solution with a primary energy efficiency of 165% (EN12309) to allow a cost-effective use of renewable energy in existing residential buildings for heating and DHW services. The project has been conceived to overcome a number of technological and non-technological barriers which

currently prevent GAHP application in single family houses or small multi-story buildings.

### Key Achievements

Results achieved in the first 18 months of the project include:

- European value chain: multi-local parametric analysis confirmed that gas absorption heat pumps offer major advantages in many European geographies (economic, energy saving, environmental and infrastructural) over competing systems for the heat supply of existing building stocks
- Appliance development: feasibility of the technical specification demonstrated by measurements on a preliminary conceptual prototype specifically developed to validate architecture and project viability; values of efficiency are maintained at levels that justify the use of this equipment in residential single application
- System control: definition of a set of simple building interfaces, overall architectures and hydraulic schemes for the optimal integration of the GAHP
- Lab performance verification: European norm for performance measure of sorption appliances (EN12309) reviewed and submitted for final publication; publication of the lab test protocol based on the prEN12309
- Decision Support System: development of a system and building model in Trnsys



### KEY FACTS

**Start date:** November 2011  
**Duration:** 36 months  
**Total budget (€):** 0.9 million  
**Website:** www.heat4u.eu  
**Coordinator:** Robur SpA, Italy  
**Partners:** France: GDF Suez, GrDF, Germany: Bosch Thermotechnik GMBH, E.ON, Fraunhofer. Italy: CF Consulting, D'Appolonia, ENEA, Pininfarina, Politecnico di Milano. Poland: Flowair. Slovenia: Zavod Za Gradbeništvo Slovenije. UK: British Gas.

### EXPECTED IMPACT

- 5 demonstrators in total (Germany, France, Italy, Poland and UK)
- 35% reduction in energy use compared to best available technology
- 5 dwellings involved and renovated
- Thousands of people reached by dissemination activity
- €9.5 million investment from project partners
- Key training actions: e-course; classes; hands on
- Hundreds of people trained
- 30% of project partners are SMEs
- 1 technology may be taken to market

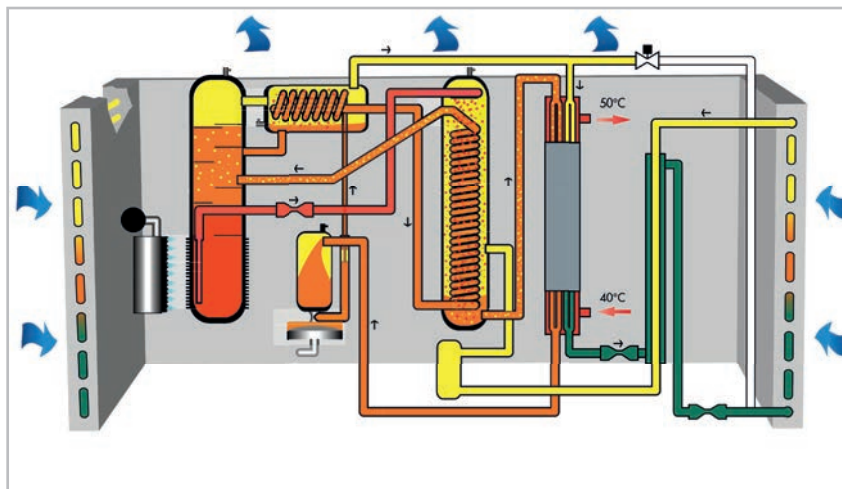

Schematic thermodynamic operating cycle of GAHP

'clear-up' presents a holistic approach to creating good indoor environments in buildings while reducing their operational energy use. Development and novel use of nano-materials and new control algorithms improve the energy performance of windows, building envelopes, air handling, heating, ventilation and lighting systems, and provide an improved indoor environment. Solutions are designed both for new builds and for retrofitting.

### Overview

In practical terms, clear-up addresses four key building components:

- Windows: clear-up advances the practical use of shutters and electrochromic windows for reducing the building's cooling load along with light-guide technology and consequently the need for artificial lighting
- Walls: clear-up uses photocatalytic materials for air purification and microporous vacuum insulation in combination with phase change materials to passively control temperature
- Air Conditioning: clear-up advances strategies for demand-controlled ventilation and improved air quality
- Sensors and control provide an underpinning technology for clear-up's approach. New sensors are in development; their use is optimised for the operation of smart windows, demand-controlled ventilation and catalytic air purification

The clear-up consortium, a cross-over from material science to the construction industry, decided to bring nanomaterials from the lab into real applications, develop sensors and control strategies for an optimal interaction, and finally integrate these new components into real buildings in order to advance not only research but also the overall 20-20-20 goal of the EU. Clear-up aims to substantially reduce savings in operational energy use without negative consequences on high quality environments for building occupants. With attention on refurbishment, clear-up solutions can bring improvements with respect to light, indoor air, and thermal comfort.

- Light: Electrochromic windows which switch transparency yet maintain outside views may help future work environments to become more comfortable while reducing the risk of overheating
- Air: clear-up will develop smart algorithms for demand-controlled ventilation based on gas sensors and photocatalytic paints may reduce the indoor pollution and required ventilation rates
- Temperature: clear-up promotes vacuum insulation panels specifically for applications where space is limited and phase change materials alter to passively control temperature

### Key Achievements

Clear-up has developed innovative technologies which will enter the market over the next few years, including:

- Cheap and energy-efficient volatile organic compound monitoring systems which monitor indoor air quality. As building regulations become stricter on airtightness in new buildings, this will be an important challenge in the near future
- Smart electrochromic glazing with high potential for energy efficiency
- Ultra efficient insulation with vacuum insulated panels and adaptability for various refurbishment cases
- Successful integration of the characterisation of these new technologies in the Building Energy Management System (BEMS) for efficient control while improving indoor comfort for users



### KEY FACTS

**Start date:** November 2008

**Duration:** 48 months

**Total budget (€):** 8.3 million

**Website:** www.clear-up.eu

**Coordinator:** University of Tübingen, Germany

**Partners:** Belgium: Belgian Building Research Institute. Czech Republic: Czech Technical University in Prague, Saint-Gobain Weber Terranova a.s. Denmark: International Centre for Indoor Environment and Energy, Technical University of Denmark. France: Bouygues Construction, Centre Scientifique et Technique du Bâtiment. Germany: Applied Sensor GmbH, Eberhard Karls University of Tübingen, Fraunhofer Institute for Solar Energy Systems, Fraunhofer Institute for Surface Engineering and Thin Films, Porextherm Dämmstoffe GmbH, Saint-Gobain Weber GmbH, Siemens Corporate Technology, Steinbeis Transfer Centre AO Action. Greece: FORTH Foundation of Research and Technology Hellas. Hungary: Budapest University of Technology and Economics. Italy: DG Joint Research Centre, European Commission, Institute for Health and Consumer Protection. Sweden: Ångström Laboratory, Uppsala University. Switzerland: Siemens Building Technology. Spain: Acciona Real Estate.

### EXPECTED IMPACT

- 4 demonstrators in total (Spain, Czech Republic, Switzerland and Greece)
- 12-34% reduction in energy use
- Estimated 800m<sup>2</sup> surface area renovated
- 18 dwellings involved and 26 end users engaged
- Estimated 20,000 people reached by dissemination activity
- €3.2 million investment from project partners
- Key training actions: Indoor Air Quality (IAQ), Life Cycle Assessment and Whole Life Costing and building management system and biomimetics in the construction industry
- 70 people trained
- 10% of project partners are SMEs
- 7 technologies may be taken to market
- 8 patents may be applied for

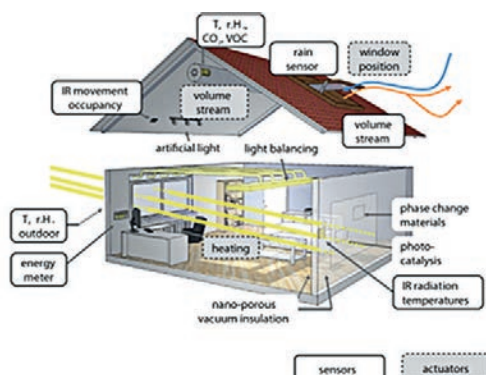

clear-up technologies for energy-optimised control of the indoor environment

## Cost-effective tools for better indoor environment in retrofitted energy efficient buildings

CETIEB develops cost-effective, innovative solutions for better monitoring of indoor environment quality and investigates active and passive systems to improve. The project seeks to ensure a wide ranging application of the resulting systems.

### Overview

Retrofitting existing building stock to meet EU targets for energy efficiency by 2020 and 2050 will lead to increasingly airtight buildings that will affect indoor air quality and the indoor environment. If effective ventilation, lighting and HVAC control systems are not integrated into the retrofit works the indoor environment could worsen with significant impacts on health, productivity and energy use.

There is a need for a cost-effective sensor system to detect and measure the indoor environment which is integrated with energy efficient control systems. There are innovative passive materials and systems which can be developed to improve the indoor environment in a cost-effective way.

CETIEB will develop these systems to allow efficient control of the indoor environment in retrofitted buildings. The objectives of the project are the following:

- Development of monitoring systems (wireless and/or partly wired) to detect indoor environmental comfort and health parameters. A modular version will be developed to allow end users to perform a quick check on the indoor air quality
- Development of control systems for indoor environments to optimise the indoor environment quality and energy efficiency by an innovative

passive plaster using photo-catalytic and phase change materials, by plant based bio-filters and by active air flow controlling components

- Modelling of the indoor environment for assessment and validation of monitored data to optimise the control parameters and systems

### Key Achievements

Main accomplishments of the project to date include:

- Identification of indoor environment quality parameters
- Cost-effective monitoring systems with advanced sensors, for VOC, CO<sub>2</sub>, light, etc.
- Infrared vision system to monitor radiating temperatures and energy fluxes, with potential for real-time extraction of thermal comfort parameters
- Intelligent architecture for active systems to control natural ventilation
- Prototype of a plant based air bio-filter
- Improved smart natural light guiding system
- Lightweight insulation mortar system with photo-catalytic plaster finish and enhanced thermal storage capacity
- 3D-simulation models with full integration of air pollutant sources and sinks
- Actual demonstration sites



### KEY FACTS

**Start date:** October 2011

**Duration:** 36 months

**Total budget (€):** 3.5 million

**Website:** www.cetieb.eu

**Coordinator:** University of Stuttgart, Germany

**Partners:** France: CEA-INES. Germany: Fraunhofer IPM, InfraTec GmbH, Schwenk Putztechnik GmbH & Co. KG, TTI GmbH – TGU Smartmote. Greece: S&B Industrial Minerals S.A., Ireland: DW EcoCo. Italy: Consorzio TRE, RED S.R.L., Stam S.R.L., Università Politecnica delle Marche. Spain: FCC Construcción S.A., Solintel. Taiwan: NTUST.

### EXPECTED IMPACT

- 6-8 demonstrators in total (France, Germany, Ireland, Italy, Spain, Taiwan)
- 2000 people reached by dissemination activity
- 50% estimated return on investment
- €1 million investment from project partners
- Key training actions: 3 workshops in Naples, Brussels and at final conference.
- 100 people trained
- 47% of project partners are SMEs
- 3-5 technologies may be taken to market
- 1 patent may be applied for

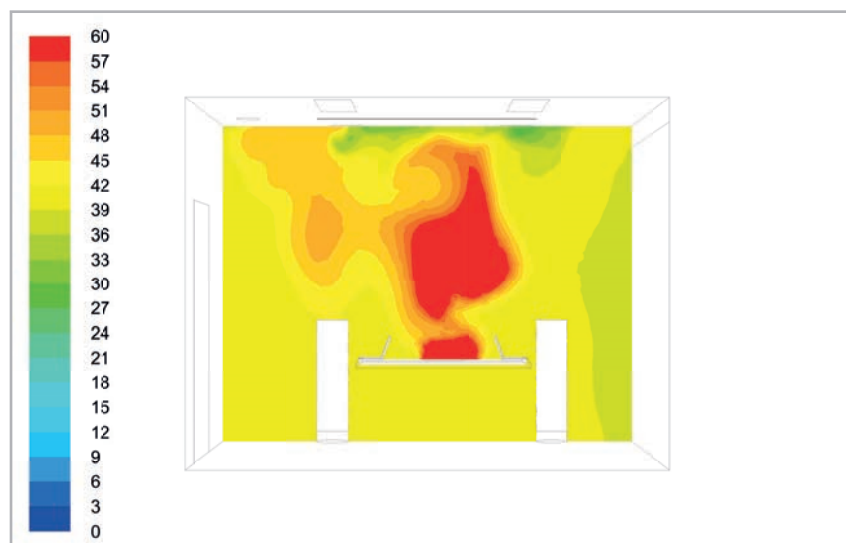

Typical office situation: distribution of pollutants from the table, colours indicate the concentration of a tracer gas (in ppm)

# INTASENSE

## Integrated air quality sensor for energy efficient environmental control

The INTASENSE project aims to develop a low cost, comprehensive, air quality monitoring system which can detect the main pollutants that contribute to poor indoor air quality: volatile organic compounds (VOCs), combustion gases and particulates. This will be utilised to aid control of HVAC systems in energy efficient buildings in order to minimise the energy requirement of the system while maintaining suitable air quality.

### Overview

Space heating accounts for more than 50% of the energy consumption of public and residential buildings. Reduction of this energy demand is a key strategy in the move to low energy/ low carbon buildings. This can be achieved by careful management of the air flow within a building through the control of inlet fresh air and exhaust air, maximising air re-circulation, and minimising the amount of fresh air which is often drawn in through a heat exchanger. However, there is a high risk that air quality is reduced. Continued exposure to environments with poor air quality is a major public health concern in both developed and developing countries. Perhaps surprisingly, remedial action to improve air quality is often easy to implement once airborne pollutants have been detected.

The project aims to develop an integrated system using novel VOC, particulate and combustion gas sensors. The integration of these separate units into a low-cost high performance unit is the key focus of the project. This is achieved by; utilising advances in micro-fluidic gas handling systems for controlled sampling, development of a bespoke wide area wireless network platform and using the experience and expertise to package and manufacture the disparate technologies.

The ultimate impact of the successful implementation of INTASENSE technologies will be an overall improvement in worker and public health through the avoidance of exposure to poor air quality as space heating efficiencies are improved through the careful control of air circulation. Moreover, in combination with existing remedial air purification and ventilation technologies, the INTASENSE air quality sensor will allow air cleaning processes to be targeted and applied only when needed, thereby improving energy efficiency and extending equipment lifetime.

### Key Achievements

- To combine innovative detection technologies to produce an air quality sensing system with advanced capabilities to provide low cost comprehensive monitoring of key airborne pollutants
- To develop a smart air quality sensing system that can engage intelligently with existing ventilation and air treatment systems to optimise energy efficiency while maintaining acceptable air quality
- To improve the health, quality of life and productivity of EU citizens by providing the means to limit citizens' exposure to poor indoor air quality



### KEY FACTS

**Start date:** October 2011

**Duration:** 36 months

**Total budget (€):** 3.3 million

**Website:** www.intasense.eu

**Coordinator:** C-Tech Innovation Ltd, UK

**Partners:** Germany: Technische Universität Ilmenau Institut für Mikro- und Nanotechnologien (TUIL). Netherlands: U.C. Technologies BV. Spain: Advantic Sistemas y Servicios, Centro de Estudios e Investigaciones Técnicas (CEIT). Switzerland: Centre Suisse d'Electronique et de Microtechnique S.A. (CSEM). UK: Gooch & Housego Ltd, Lancaster University.

### EXPECTED IMPACT

- 1 demonstrator in total (location to be decided)
- 5 possible end users engaged
- Estimated 2000 people reached by dissemination activity
- €0.9 million investment from project partners
- Key training actions: Indoor Air Quality (October 2011), Wireless Sensor Networks (March 2012), Detection & monitoring of particulates (September 2012).
- 23 people trained
- 37.5% of project partners are SMEs
- 4 technologies may be taken to market
- 2 patents may be applied for

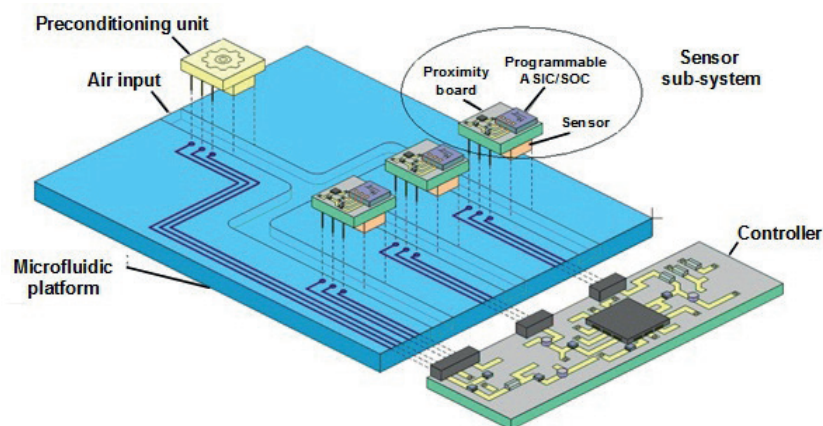

Schematic of INTASENSE integrated air quality sensor

# EnE-HVAC

## Overview

In residential and commercial buildings HVAC systems constitute about 35% of the total energy consumption. Although heating is the most energy demanding need today, there is an increasing demand for cooling. This is expected to increase even further in the years to come due to climate change. To decrease overall energy demand it is vital to look for new and innovative technologies that improve the efficiency of currently applied state-of-the-art HVAC systems.

Through this project, we will demonstrate energy savings of up to 50% on the total energy consumption in an HVAC system compared to current conventional commercially available systems. To achieve these savings, the EnE-HVAC project will tackle all aspects of the system, using novel nano-technological

## Energy efficient heat exchangers for HVAC applications

The EnE-HVAC project will achieve significant energy savings in future Heating, Ventilation, and Air Conditioning (HVAC) systems via new and innovative technologies. These technologies include nano-technological coatings and surface treatments for improved heat transfer; new nano- and micro-materials for improved efficiency of the refrigerants, and improved efficiency and heat transfer capabilities of coolants via new nano-technological additives.

approaches, improving heat transfer and transport throughout the whole system. These new technologies are:

- Nanostructured coatings including Sol-gels and PVD coatings which increase heat transfer
- Nano technological coatings with anti-freeze properties to limit over icing of heat exchangers

- Nano fluids for the improvement of heat transportation

### KEY FACTS

**Start date:** October 2012  
**Duration:** 36 months  
**Total budget (€):** 4.2 million  
**Website:** www.ene-hvac.eu  
**Coordinator:** Danish Technological Institute, Denmark  
**Partners:** Denmark: Danish Heatpump Industry, EXHAUSTO A/S. Finland: Carboeoon Oy, Vahterus Oy. Germany: ESI Group. Italy: LuVe S.p.a. Spain: IK4 Tekniker.

### EXPECTED IMPACT

- 2-4 demonstrators in total (locations still to be decided)
- 50% reduction in energy use and 0,25Mt per year CO<sub>2</sub> savings
- More than 100,000 people reached by dissemination activity
- €1.3 million investment from project partners
- 25% of project partners are SMEs
- 5-8 technologies may be taken to market
- 3-5 patents may be applied for

# NANOCOOL

## Overview

AC is a rapidly growing electrical end-use in the EU. AC systems reduce the temperature of the ambient air while removing humidity. However, such combined AC/dehumidification is generally inefficient. A promising approach is represented by Hybrid Liquid Desiccant (HLD) systems, where the latent load is removed by a liquid desiccant dehumidifier, while the sensible load is removed by a conventional vapor compression air cooler. However, the heat required for regeneration of the liquid desiccants needs to be provided by external sources such as natural gas or solar collectors. Furthermore, almost all metal alloys are corroded by the most effective liquid desiccants. Hence HLD systems are not penetrating the market. Nanocool aims to reduce the capital and operational costs of air conditioning systems by developing an HLD system in

## Energy efficient air conditioning system with temperature and humidity independent controls combining liquid desiccant cycle with an adapted conventional air cooling system

The aim of Nanocool is to develop an innovative hybrid liquid desiccant air conditioning (AC) system with independent temperature and humidity controls. The latent load is removed by a liquid desiccant dehumidifier, while the sensible load is removed by a conventional AC system. Thermally conductive polymer nano-composites will be considered as materials for the components of the liquid desiccant cycle.

which waste heat from the condenser is used for regeneration of the desiccants. Multifunctional heat exchangers with high corrosion resistance will be developed for the liquid desiccant cycle, making use of polymer nano-composites and shaped into innovatively engineered heat exchange surfaces.



### KEY FACTS

**Name of project:** NANOCOOL  
**Start date:** September 2012  
**Duration:** 42 months  
**Total budget (€):** 5 million  
**Website:** www.nanocoolproject.eu  
**Coordinator:** Tecnalia, Spain  
**Partners:** Czech Republic: Fenix. Germany: SGL Carbon. Israel: Technion. Italy: D'Appolonia, Decsa, Politecnico di Torino, Stam. Poland: Ridan. Spain: Airlan, Universitat Rovira I Virgili. Taiwan: TBTC.

### EXPECTED IMPACT

- 2 demonstrators in total (locations to be confirmed)
- 50% reduction in energy use and 0.045 Mt/year CO<sub>2</sub> savings
- 1000 people reached by dissemination activity
- €1.7 million investment from project partners
- Key actions: Training of the SMEs in the construction sector responsible for the mounting and installation of HVAC systems
- 5 project partners are SMEs
- 3 technologies may be taken to market
- 3 patents may be applied for

# NANO-HVAC

## Overview

HVAC systems represent almost 33% of energy use in commercial facilities (14% space heating, 10% space cooling and 9% ventilation). Cooling trends are expected to increase due to climate change and an increased presence of heat releasing equipment in buildings. Ventilation is also a concern for safety reasons. In many industrial and commercial buildings, hospitals, long-term care facilities and other institutional structures, only 10-15% of the indoor air is fresh with the remaining portion being recirculated air due to energy efficiency considerations. Large numbers of people spend many hours each day in these environments, potentially being exposed to low quality air which can lead to an increased presence of allergies or even respiratory diseases.

## Novel nano-enabled energy efficient and safe HVAC ducts and systems contributing to a healthier indoor environment

The NANO-HVAC project aims to develop an innovative approach for duct insulation while introducing new cleaning and maintenance technologies, all enabled by cost-effective application of Nanotechnology. The system will comprise an innovative lighting system for a TiO<sub>2</sub> sprayed filter which will purify the ducts, plus a sprayable aeroclay-based insulating foam and a liquid polymer matrix for optimised traditional maintenance activities.

In this context there is urgent need for novel energy efficient and safe HVAC solutions which are able to provide healthier indoor environments.

The project aims to address the major challenge in ventilation systems related to poor air quality, through its set of anti-microbial and anti-allergic solutions and strategies for increased indoor comfort.



### KEY FACTS

**Start date:** September 2012  
**Duration:** 36 months  
**Total budget (€):** 2.8 million  
**Website:** [www.nanohvac.eu](http://www.nanohvac.eu)  
**Coordinator:** Vento NV, Belgium  
**Partners:** Belgium: SIRRIS. Greece: Nanophos, NTUA. Italy: D'Appolonia SpA, Farbe SpA, Politecnico di Milano. Portugal: INL. Romania: ICAA. Spain: Acciona, Aidico.

### EXPECTED IMPACT

- 1 demonstrator in total (Spain)
- 50% savings in energy losses
- 36% of project partners are SMEs
- 3 technologies may be taken to market
- 4 patents may be applied for

# HarWin

## Overview

Energy consumption of buildings will remain a major concern for the world population in decades to come. In all types of buildings the overall energy consumption can be significantly improved by optimising the heat accumulation and heat loss of facades and windows. Increasing the degree of sunlight utilisation in buildings has been recognised as an important asset for technical and cultural progress in human societies.

The HarWin concept aims to develop multi-purpose windows based on laminated composites made from new materials not yet utilised for glazing. These new laminated composites are light-weight structures made from thin glass panes which will be joined together with newly developed light transparent polymer-composite sheets containing glass particles. The role of these particles

## Harvesting solar energy with multifunctional glass-polymer windows

HarWin will develop new materials for windows and provide heat and noise control through laminate glazing structures and lightweight framing. Phase-changing materials will improve energy efficiency and materials for wavelength conversion will enhance visible light transmission. Benefits of the next generation windows will be a reduction in weight, thermal conductivity and energy and material consumption, proved through a lifecycle environmental assessment.

is to provide visual, thermal and sound functionality as well as mechanical reinforcement. The major objective is to decouple the material properties which are responsible for light transmission from properties which enable heat and sound insulation. This will be achieved by a new type of polymer-glass composite material used for glazing.



### KEY FACTS

**Start date:** September 2012  
**Duration:** 36 months  
**Total budget (€):** 4.9 million  
**Website:** [www.harwin-fp7.eu](http://www.harwin-fp7.eu)  
**Coordinator:** University of Bayreuth, Germany  
**Partners:** Belgium: Isomatex SA, Joint Research Centre- European Commission. Finland: Eckart Pigments KY. Germany: BayFOR, Centrosolar Glas GmbH & Co. KG, Fraunhofer ISC, InGlas Produktions GmbH. Poland: Zachodniopomorski Uniwersytet Technologiczny w Szczecinie. Switzerland: GlassX AG. UK: Integrated Environmental Solutions Ltd.

### EXPECTED IMPACT

- €700,000 investment from the industrial project partners
- Key training actions: workshops, hand-on training on processing of composites and laminates
- 10 people trained
- 36% of project partners are SMEs
- 3-5 technologies may be taken to market
- 5-10 patents may be applied for

# MEM4WIN

## Ultra-thin glass membranes for advanced, adjustable and affordable quadruple glazing windows for zero-energy buildings

MEM4WIN aims to develop windows which provide weight savings and energy control and harvesting. The project will introduce a novel insulated glass unit for quadruple glazing containing ultra-thin glass membranes for frameless openable windows with direct installation in facades. The project will implement printed organic photovoltaics (OPVs) and solar thermal collectors for energy harvesting and micro mirrors for energy control and advanced day lighting.

### Overview

Buildings are responsible for 40% of energy consumption and 36% of EU CO<sub>2</sub> emissions. The European Commission's Energy Efficiency programme has identified that buildings provide the largest potential for cost-effective energy saving. In order to reach the EU 2020 goal of increasing energy efficiency by 20%, insufficient insulating windows have to be replaced by energy efficient, smart and energy harvesting windows in all member states. The MEM4WIN window introduces appropriate technology which will help reach this target without reducing comfort while providing cost savings. Fabrication costs will be reduced by replacing conventional and cost intensive materials used for contacts (like ITO and silver) by graphene. Production methods such as roll-to-plate and ink-jet printing will be introduced to fabricate contacts for OPVs. The various

components such as micro-mirrors, OPVs, organic light emitting diodes (OLEDs) and solar thermal collectors will be integrated into a demonstrator at the end of the project, presenting the suitability of the used equipment, processes and new materials.



#### KEY FACTS

**Start date:** October 2012  
**Duration:** 42 months  
**Total budget (€):** 6.6 million  
**Website:** [www.mem4win.com](http://www.mem4win.com)  
**Coordinator:** LISEC INOVA Technologiezentrum GmbH, Austria  
**Partners:** Austria: Durst, Profactor, Tiger, University Linz. Germany: Aixtron, Belectric, Energy Glas, University Kassel. Italy: CNR, Durst. South Korea: University South Korea. UK: Aixtron, University Cambridge.

#### EXPECTED IMPACT

- 2 demonstrators in total (Austria and Germany)
- 50% reduction in energy use
- 100,000m<sup>2</sup> surface area renovated
- 500,000m<sup>2</sup> new build efficient area in 2017
- More than 6,000 dwellings involved
- More than 10,000 people reached by dissemination activity
- Estimated 150% return on investment
- More than €2.5 million investment from project partners
- More than 50 people trained
- 30% of project partners are SMEs
- 5 technologies may be taken to market
- 3 patents may be applied for

# SmartBlind

## Development of an active film for smart windows with inkjet method and an application to an autonomous smart device for buildings

The SMARTBLIND project aims to develop an energy efficient smart window. The window will include a hybrid film composed of an electrochromic film and a photovoltaic film printed onto a long-lasting flexible substrate. The realisation process will be implemented thanks to electrochromic and photovoltaic inks specially formulated to be ink-jet printed.

### Overview

The consortium aims to produce a hybrid flexible film and energy saving window (with single or multiple panes) that could enter the new-build and renovation markets. To promote an autonomous system, the consortium brings together many disciplines (including polymer chemistry and physics, electronics, modelling, building engineering and architecture) coming from public and private research ecosystems.

surfaces  
The main steps of the work plan include:

- Basic materials: substrate treatment, formulation of electrochromic and photovoltaic inks adapted for inkjet printing
- Printing process
- Simulation and building integration
- Mechanical tests, ageing and Life Cycle Assessments
- Proof of concept



#### KEY FACTS

**Start date:** September 2012  
**Duration:** 36 months  
**Total budget (€):** 5.2 million  
**Website:** [www.smartblind-project.eu](http://www.smartblind-project.eu)  
**Coordinator:** Polymage, France  
**Partners:** Belgium: VUB. France: Ardeje, CEA-INES, Kurt Salmon, Polymage. Germany: DITF. Poland: Politechnika Lodzka. Portugal: A Catedral, FFCT. Romania: Termoglass. Spain: FCC Construccion, IASO, LEITAT.

#### EXPECTED IMPACT

- 3 demonstrators in total (Romania, Portugal and Spain)
- €1.5 million investment from project partners
- Key actions: Exploitation strategy seminar, internal workshop on "Energy plus" and "Radiance"
- 39 people trained
- 38% of project partners are SMEs
- 2 technologies may be taken to market
- 2 patents may be applied for

The SmartBlind consortium has 4 main objectives:

- To reduce the weight by 50% when compared with glass windows, while offering transparency and flexibility
- To improve the optical response time of windows while enabling the switching to larger panes
- To integrate an electronic control system with an embedded power source
- To guarantee a low-cost industrial solution adaptable to large and shaped

# Winsmart

## Smart, lightweight, cost-effective and energy efficient windows based on novel material combinations

The main aim of the project is to create “smart active” windows that reduce heat loss by 75% and contribute to meeting the energy efficiency targets of the building industry by 2020. This goal will be achieved through a new Vacuum Insulation Glazing (VIG) solution combined with newly developed switchable glazing systems mounted in a durable and energy efficient sash and frame.

### Overview

As up to 60% of heat loss in buildings comes from windows, there is much to gain in optimising them in properties. EU 2020 goals mean that future windows must be distinctively better than today's in terms of heat loss and control of heat gain from sunlight. Low-energy windows with triple glazing have a heat loss U-value of approximately 0.8. Winsmart aims to reach 0.3 while at the same time reducing the weight of the windows.

Drastic improvements in the glazing and sash/frame are needed to meet these goals. Modern windows are filled with gas, however better insulation can be obtained by creating a vacuum. The challenge of VIG is to ensure the seal is tight enough to avoid leakage. In addition, “smart active” solar control, which prevents overheating, will be included. The project will use highly

insulating and bio-based materials for the sash and frame construction, to improve both sustainability and energy performance (e.g. embodied energy). These technologies should be ready for marketing within 5-8 years.



### KEY FACTS

**Start date:** October 2012

**Duration:** 48 months

**Total budget (€):** 5 million

**Website:** [www.winsmart.eu](http://www.winsmart.eu)

**Coordinator:** Danish Technological Institute, Denmark

**Partners:** Belgium: AGC Glass Europe. Denmark: IdealCombi A/S, Photosolar A/S. Germany: EControl-Glas GmbH & Co., Fraunhofer. Switzerland: EMPA. Slovenia: University of Ljubljana.

### EXPECTED IMPACT

- 2 demonstrators in total (Denmark)
- 50% reduction in energy use per unit
- €1.2 million investment from project partners
- 25% of project partners are SMEs
- Estimated 5 technologies may be taken to market
- 2 patents minimum may be applied for

## Operational guidance for life cycle assessment studies of the energy efficient buildings initiative

The European research project EeBGuide develops guidance for the preparation of Life Cycle Assessment (LCA) studies for energy efficient buildings and building products. The EeBGuide manuals give pragmatic and relevant guidance to practitioners and construction experts on how to move forward in the field of LCA towards comparative, meaningful results both within individual studies and between them.

### Overview

The construction industry is a large contributor to CO<sub>2</sub> emissions, with buildings responsible for 40% of the total European energy consumption and a third of CO<sub>2</sub> emissions. At the same time, the construction industry provides work for over 12.7 million people in the EU7 and generates about one fifth (20.3 %) of the combined industrial and construction sectors' value added.

The EeBGuide document provides a common methodology supporting reliable assessment and comparison of buildings and products. Previous LCA studies indicated inconsistencies with a lack of comparison between different studies. Research into innovative products and low energy buildings are crucial in facing challenges in LCA. Based on existing standards, guidelines and the International Reference Life Cycle Data System (ILCD) Handbook, the project partners developed a common methodology for conducting LCA studies within the Energy Efficient Building Initiative. The focus of the EeBGuide particularly lies on case study examples and operational guidance provided by LCA experts and practitioners for easy application. One of the key project objectives is to demonstrate the applicability of the guidance in practice.

The core elements of the guide are published as an interactive, web-based tool. The EeBGuide enables private and public LCA practitioners to quantify environmental impacts in a consistent manner. The guidance document can be applied to assess the life cycle of whole buildings, building products and technological solutions awaiting development within the E2B Initiative. It allows practitioners to perform LCAs in a clear, pre-defined and well-structured way by delivering a scientifically sound, and quality assured guidance which can be used for practical applications.

### Key Achievements

The final guidance document includes 173 important LCA aspects which are explained in detail. Where possible, suggestions are made based on the ILCD Handbook and standards. In addition, guidance from LCA experts across Europe is given in order to enhance the suggestion provided. These aspects were chosen in several project workshops with LCA experts and practitioners from various fields. The applicability of the developed guidance document was demonstrated by conducting case studies. In total six case studies - two on building products and four on buildings - were conducted.



#### KEY FACTS

**Start date:** November 2011  
**Duration:** 12 months  
**Total budget (€):** 0.8 million  
**Website:** [www.eebguide.eu](http://www.eebguide.eu)  
**Coordinator:** Fraunhofer IBP, Germany  
**Partners:** France: Centre Scientifique et Technique du Bâtiment. Germany: Fraunhofer Institute for Building Physics IBP, PE International. Spain: Escola Superior de Comerç Internacional. Sweden: Prof. Ch. Sjöström Consultancy. UK: BRE Global Limited.

#### EXPECTED IMPACT

- 3 demonstrators in total (France, Spain and Germany)
- 2,500 people reached by dissemination activity
- Key training actions: Development of training materials and two video tutorials. One training session in Paris and one in Madrid
- 21 people trained
- 20% of project partners are SMEs



Guide for Life Cycle Assessment studies

## Geo-clustering to deploy the potential of energy efficient buildings across the EU

Based on the concept of geo-clusters firstly introduced by E2BA in its “Scope and Vision” document, the aim of this project is to develop a proof of concept for a Geo-cluster approach by means of a Geo-cluster Mapping Tool. This tool will guide stakeholders and policy makers towards the implementation of effective energy efficiency solutions in the built environment.

### Overview

Buildings account for 40% of Europe’s energy use and a third of its greenhouse gas emissions. Improving energy efficiency measures in the built environment is thus of great importance in responding to climate change and EU 2020 goals in particular. Within this framework, experts acknowledge that relevant stakeholders such as large industrial players, SMEs, research centres and NGOs must be brought together and work in close cooperation. It is also imperative to adapt energy efficient solutions to regional and local scales.

The GE<sup>2</sup>O project aims to develop a Geo-cluster Mapping Tool consisting of a multi-dimensional and dynamic Geographic Information System that enables its users to combine single or multiple parameters organised in homogeneous layers and sub-layers, addressing both technological and non-technological aspects. This will aid the identification of virtual transnational areas where strong similarities are found in terms of climate, construction typologies, energy prices and regulations.

In addition, the project strives to establish stakeholders’ communities across identified European virtual transnational areas that are interested in the continuous growth and exchange of structured information. It also seeks to develop an extensive shared workspace and knowledge repository to support networking among these communities.

### Key Achievements

Achievements to date include:

- Identification of 56 European clusters operating in the field of energy efficiency
- Identification of six layers gathering homogeneous indicators and parameters identified during the analysis including technological, climate, socio-economic, building typologies, regulation and financial incentives
- Due to time constraints and the difficulty in gathering accurate data, it was decided the project would focus on two predefined key technologies: Thermal insulation (Benelux) and Solar Cooling (Mediterranean arc). A methodology to correlate different layers and sub-layers was validated for these technologies
- A working version of the GeoCluster Mapping Tool is available at [www.geoclusters.eu/ge2o](http://www.geoclusters.eu/ge2o)



### KEY FACTS

**Start date:** January 2012

**Duration:** 48 months

**Total budget (€):** 1 million

**Website:** [www.geoclusters.eu](http://www.geoclusters.eu)

**Coordinator:** CSTB, France

**Partners:** Belgium: BBRI, E2BA. Czech Republic: TZUS. Italy: D’Appolonia, Polimi. Luxembourg: Arcelor Mittal. Netherlands: TNO. Poland: ASM. Slovenia: ZAG. Spain: Acciona. UK: IFS.

### EXPECTED IMPACT

- The availability of an extensive set of validated data and indicators for key geographical areas will allow requirements and specifications for technology development and integration to be properly defined, as well as the fine tuning of demonstration actions in order to maximise impact
- Non-technological aspects will be instrumental for the full take up of the geo-clusters concept and should be able to leverage the expected outcomes
- Direct/indirect involvement of a wide range of stakeholders guided by a clear industrial vision and a comprehensive coverage of the industrial value chain in energy-efficient buildings will be considered. The project builds on an industry driven approach and compliments industrial knowledge with a deep understanding of the built environment, behavioural aspects, etc. brought in by the highly renowned building research partners and the networks they represent, namely ECTP, ENBRI and ECCREDI.

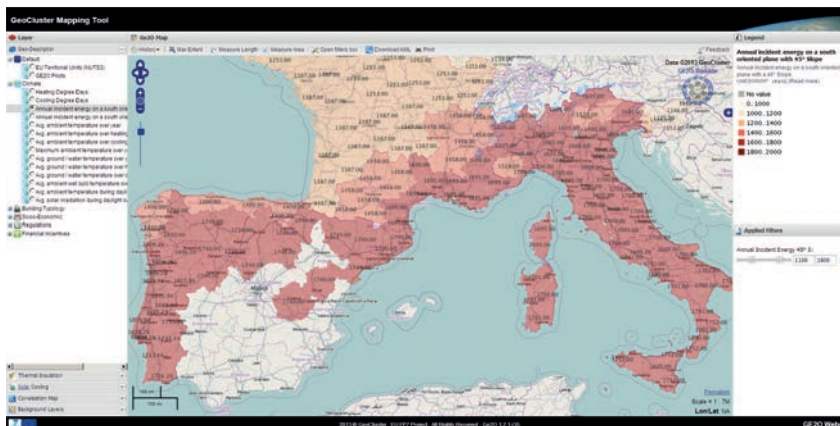

Annual incident energy on a south oriented plane with 45° slope in kWh/m<sup>2</sup>

# ee-WiSE

## Overview

As a result of the European targets defined to achieve environmental goals, the energy efficient retrofitting building sector has grown. Countries in the Mediterranean region have been some of the last to take up this sector thus presenting specific knowledge transfer breakpoints and special energy saving needs within the value chain.

The ee-WiSE framework is designed to overcome barriers across the sector. In the initial stages, agents of the value chain are identified and current energy efficiency knowledge practices studied. The agents' behaviour is then analysed with the participation of Mediterranean stakeholders, to detect knowledge transfer gaps, energy efficiency needs and best practices.

## Energy efficiency knowledge transfer framework for building retrofitting in the Mediterranean area

The ee-WiSE project aims to develop a knowledge transfer framework in the value chain of retrofitting buildings within the energy efficiency sector. The activities and tools developed will improve communication flows throughout the Mediterranean area. Economic growth and new business opportunities for SMEs will develop while achieving environmental goals.

The knowledge transfer framework will provide useful tools and guidelines to share knowledge on practices, technologies, strategies and services. These activities will boost business models, promote energy efficiency market up-take, improve cross-sectorial cooperation, and assist in the promotion of energy efficiency policies.

The project was conceived in order to address energy efficient competitive



agents and user demands. The consortium is a balanced representation of agents and countries with a superior participation of SMEs.

### KEY FACTS

**Start date:** October 2012  
**Duration:** 24 months  
**Total budget (€):** 1.2 million  
**Website:** www.ee-wise.eu  
**Coordinator:** INTROMAC, Spain  
**Partners:** Bulgaria: Bulgarian Construction Chamber. Cyprus: IMA Architecture, X-Panel. Greece: AVACA Technologies, Harbour of Rafina, Positive Energy. Italy: ANCE, ISTDIL. Malta:

Projects in Motion. Spain: AIDICO, ENERCYA, EOLAS. Turkey: EGE University.

### EXPECTED IMPACT

- 54% of project partners are SMEs
- The knowledge transfer framework will be shaped by interacting with the value chain, considering feedback in survey activities, workshops and the validation stage during the project.

# ENBUS

## Overview

The Smartphone App will offer a new way for people to access information about energy efficient technologies and products. One tool developed as part of the App is the Simplified Energy Profile (SEP). SEP provides an easy way to describe the energy efficiency of a product, with necessary data from the company marketing the product. ENBUS will compile the data given by the company and make it accessible to as many clients as possible by creating an Iphone App and a web based application. It will be possible to search for specific products or features of a product in the App.

In the first step ENBUS will focus mainly on a selected number of product groups including: windows, heating systems, ventilation and insulation for family

## Energising the building sector

The construction, maintenance and operation of buildings are some of Europe's most energy consuming activities. To create change in this area, the European collaboration project ENBUS will spread awareness, motivation and information about energy efficiency within the building supply chain. The main focus of the project will centre on a series of seminars and workshops, and the launch of a Smartphone Application.

houses and apartment houses under renovation.

The first 25 SEPs out of 50 planned have been completed. The aim of ENBUS is to develop an App that will be graded as attractive by the user groups as well as by the companies producing energy efficient products.



### KEY FACTS

**Start date:** September 2012  
**Duration:** 30 months  
**Total budget (€):** 1.3 million  
**Website:** www.enbus.eu  
**Coordinator:** Swerea IVF, Sweden  
**Partners:** Denmark: Teknologisk Institut. Germany: Fraunhofer. Netherlands: Innovatienetwerk Voor Ondernemers. Stichting Syntens. Poland: Dolnoslaski Park Innowacji I Nauki S.A. Sweden: SP Technical Research Institute of Sweden.

### EXPECTED IMPACT

- The developed App within the ENBUS project will not reach its final stage in this project. Rather, it should be seen as a prototype for a future application. In order to be an attractive App giving advice for the best energy saving products, there will be a need for continuous updating in the future.
- Key training actions: 10 workshops, one matchmaking event and one transnational mission

# E-hub

## Energy-hub for residential and commercial districts and transport

E-hub develops a new type of district energy infrastructure which will include an advanced control system for matching supply and demand of energy (heat, cold and electricity). Advanced heat storage technologies such as Thermo Chemical Materials (TCM's) and distributed storage have been incorporated into the project. Demonstration of the technology will occur at full scale in the Tweewaters district, Belgium.

### Overview

To achieve low energy or energy neutral districts, renewable energy shares must increase dramatically above present levels. The fluctuating character of renewable energy production makes accommodating a large supplier of renewable energy (such as an array of wind turbines) complicated. As a result, renewable energy supply is either too large or too small to cover instantaneous energy demand. The presence of both smart energy management systems and energy storage is crucial to meet this challenge.

The E-hub project aims to maximise the amount of renewable energy in a district by matching energy demand and supply, by shifting in time the demand of heat pumps, refrigerators or washing machines. Excess renewable heat can be stored either in advanced Thermo-Chemical Materials (TCM) for prolonged periods with little heat loss, or in distributed storage vessels or boreholes. Acceptance of advanced energy systems by energy suppliers and users is an important element of the project. Therefore, developing new business models and service concepts that are attractive to all stakeholders is essential.

The E-hub energy system will be demonstrated in the Tweewaters district in Leuven, Belgium. Additionally, a lab demonstration will be carried out at the university campus in Genova. Four scenario studies will then be carried out to assess the feasibility of an E-hub type system in the districts of Amsterdam (Netherlands), Freiburg (Germany), Bergamo (Italy) and Dalian (China).

### Key achievements

Pivotal work has occurred on smart energy management, whereby the control algorithm (the "Multi Commodity Matcher") has been developed and reported. Most of the simulation environment being developed to test the control algorithm is finished. Component models are being debugged and tested. Preparations for the control algorithm in the case studies as well as in the lab demonstration are underway with no major setbacks. The full scale demonstration in Tweewaters is proceeding to schedule with the smart energy system expected to go live in September 2013. Good progress has also been made on advanced thermal storage and new business models.



### KEY FACTS

**Start date:** December 2010  
**Duration:** 48 months  
**Total budget (€):** 11.7 million  
**Website:** [www.e-hub.org](http://www.e-hub.org)  
**Coordinator:** TNO, Netherlands  
**Partners:** Belgium: Ertzberg, ISPE, VITO. Finland: VTT. France: EDF. Germany: Fraunhofer-ISE, HSW. Italy: D'Appolonia, Finlombarda, University of Genoa. Netherlands: ECN. Poland: Mostostal. Spain: Acciona, Solintel. UK: ICAX.

### EXPECTED IMPACT

- 2 demonstrators in total (Belgium and Italy)
- 80-100% reduction in energy use 520t per year CO<sub>2</sub> savings
- 12,000m<sup>2</sup> new build efficient area
- 106 dwellings and 14 shops involved
- 300 end users engaged
- 300 reached by dissemination activity (direct), several thousand (from numerous lectures on the project)
- 5% estimate return on investment
- €2.3 million investment from project partners
- 50 people trained
- 25% of project partners are SMEs
- 2 technologies may be taken to market



"De Balk van Beel" apartment building in Leuven, Belgium where a smart energy management system is being installed

# FC-DISTRICT

## New micro-combined heat and power network technologies for energy efficient and sustainable districts

FC-DISTRICT optimises and implements an innovative energy production and distribution concept for sustainable and energy efficient districts. The concept is based on dynamic heat exchange between buildings exploiting Solid Oxide Fuel Cell (SOFC) based micro-combined heat and power (CHP) units for energy production, improved thermal storage, building and piping insulation, biogas production from food waste, smart control and hybrid wireless network systems.

### Overview

FC-DISTRICT addresses refurbished and/or new “energy autonomous” districts, exploiting decentralised co-generation coupled with optimised building and district heat storage and intelligent district distribution networks. Continuous SOFC operation along with effective in-building and district load control is expected to reduce annual primary energy consumption at district level by up to 60%. Demonstrations are undertaken in Spain, Greece and Poland in three phases: unit, building and district.

The FC-DISTRICT objectives are:

- Develop a high temperature SOFC with versatile fuel processor and optimised peripheries making successful integration with district networks possible. CHP production and efficient fuel use results in reductions in carbon emissions and costs, savings in losses over long transmission and distribution lines. It offsets the use of centrally-generated electricity from the grid and allows local voltage regulation.
- Develop and implement advanced, durable and cost effective insulation materials for improved thermal responses in building and district piping

- Integrate food waste disposers with anaerobic digesters to produce biogas
- Implement an “Intelligent Heat Network” equipped with smart control and hybrid wireless network systems
- Optimise and tailor the characteristics of the energy and power distribution systems to meet the energy and power demand of various building and district typologies

### Key Achievements

- Micro-CHP System: New SOFC based micro-CHP configuration currently under construction. It nominally provides 1.5 kWel and 2.75 kWth with a 5-7 year return on investment. Technical developments closely follow the current EU state of the art in the field.
- Patented off-gas burner.
- New External Thermal Insulation Compound (ETIC) Systems based on Vacuum Insulation Panels (VIP) coupled with dry wall construction and Phase Change Material (PCM)-boards have been developed and are demonstrated at two demonstration sites in Greece. Monitoring results are available online: [http://demohouse.hmcs.mech.ntua.gr/demohouse\\_site/?lang=en\\_us](http://demohouse.hmcs.mech.ntua.gr/demohouse_site/?lang=en_us).
- New VIP based hybrid insulated pipe prototypes and production scheme
- Innovative biogas tanks. Significant step forward towards commercialisation of tank prototype with new control system. Market potentials established.
- New models for district heating including supply of heat, networks, buildings and consumer behaviour
- One year demonstration planned in Poland to validate the energy-autonomous district concept



### KEY FACTS

**Start date:** September 2010

**Duration:** 48 months

**Total budget (€):** 11.8 million

**Website:** [www.fc-district.eu](http://www.fc-district.eu)

**Coordinator:** Mostostal Warszawa S.A., Poland

**Partners:** Belgium: Intesa SanPaolo Eurodesk. Germany: TU-BAF, KNAUF Gips, EBZ, Sunfire. Greece: NTUA, KNAUF Gypospopia ABEE. Italy: D'Appolonia, ecofast. Netherlands: ECN, vito. Poland: IEN. Portugal: IST. Romania: OVM ICCPET. Spain: Acciona, Fagor, Ikerlan, Solintel M&P. Sweden: CUT, Powerpipe, SP., U.K: Rinicom.

### EXPECTED IMPACT

- 3 demonstrators in total (Spain, Greece and Poland)
- Estimated 55% reduction in energy use and 3.8kt CO<sub>2</sub> savings per year (referring to 1 km<sup>2</sup> of residential district)
- Estimated 2800 dwellings involved
- More than 5,000 people reached by dissemination activity
- Estimated 5-7 year payback on investment for micro-CHP, 10 years for hybrid insulation pipes, VIP ETICS and biogas tanks
- Key training actions: 20 project presentations in public events, 8 journal publications, 23 presentations in international conferences and training of Greek energy auditors on project construction concepts
- More than 1000 people trained
- 44% of project partners are SMEs
- 4 technologies may be taken to market
- 3 patents may be applied for



The FC-DISTRICT concept and achievements

## EU-GUGLE

### European cities serving as green urban gateways towards leadership in sustainable energy

Within the EU-GUGLE project six European cities, Vienna, Aachen, Milan, Sestao, Tampere and Bratislava, together with the associated cities of Gothenburg and Gaziantep have committed to renovate a total of 226,000m<sup>2</sup> of existing buildings, aiming to demonstrate the feasibility of nearly zero-energy building renovation models in European smart cities and communities by 2020.

#### Overview

Taking on the challenge of sustainable renovation in urban areas, six EU-GUGLE smart districts will renovate a total of 226,000m<sup>2</sup> of living space, with the objective of achieving 40 to 80% of primary energy savings per pilot district, increasing the share of renewable energy sources by 25% by 2018.

To reach this objective, the six pilot districts and two associated cities will join efforts to combine the latest research results relevant to smart renovation of buildings at district level and use this knowledge to implement a balanced mix of technical, socio-economic and financial solutions adapted to local needs. All aspects of the renovation process will be monitored and evaluated, from the energy performance of the renovated buildings to financing schemes chosen by the municipalities.

The project is part of the Smart Cities and Communities Initiative of the European Commission, which aims to foster the EU-wide dissemination of the most efficient models and strategies for helping cities and communities to achieve a 40% greenhouse gas emissions reduction by 2020.



#### KEY FACTS

**Start date:** April 2013  
**Duration:** 60 months  
**Total budget (€):** 30.1 million  
**Website:** www.eu-gugle.eu  
**Coordinator:** National Renewable Energy Centre of Spain (Cener), Spain  
**Partners:** Austria: City of Vienna, IC Group, University for Natural Resources and Life Sciences (BOKU). Belgium: Greenovate! Europe. Finland: City of Tampere, Technical research centre of Finland (VTI). Germany: City of Aachen, Gewoge Aachen, Stadtwerke Aachen, Synergiekomm. Italy: Aler Milano, City of Milan, Politecnico di Milano. Slovakia: Building Testing and Research

Institute (TSUS), City of Bratislava, Green Building Council Slovakia (SKGBC). Spain: Ente Vasco de la Energía (EVE), Sestaoberri 2010. Sweden: City of Gothenburg. Turkey: Gaziantep Metropolitan Municipality.

#### EXPECTED IMPACT

- 6 demonstrators in total (Austria, Germany, Italy, Spain, Finland and Slovakia)
- 40-80% reduction in energy use and 5.6 Mt per year CO<sub>2</sub> savings
- 226,000m<sup>2</sup> renovated surface area
- 3,121 dwellings involved and 11,292 end users engaged
- €13.4 million investment from project partners

## R2CITIES

### Renovation of residential urban spaces: towards nearly zero-energy cities

R2CITIES aims to develop and demonstrate an open and easily replicable strategy for designing, constructing, and managing large scale district renovation projects to achieve nearly zero-energy cities. For this purpose, a demonstration and dissemination framework of innovative strategies and solutions for building energy renovation at district level will be developed.

#### Overview

R2CITIES involves three cities committed to the Smart Cities challenges and objectives: Valladolid, Genoa and Kartal (Istanbul). Addressing the renovation of buildings at district scale, integrated and systemic design approaches can benefit from economies of scale, cost effectiveness, new business models and an appropriate stakeholder involvement.

The R2CITIES framework will be validated by a strong demonstration programme, envisaging the renovation of 57,000m<sup>2</sup> of residential buildings, focusing on the following pillars:

- Three demonstrations of residential district retrofitting, located in different countries with different climate conditions, user habits, etc.
- Several studies of cost-effective solutions for the holistic improvement of energy performance at district level, considering:
  - standard indicators
  - new diagnostic approach

- analysis of existing energy technologies (following a systemic approach)
- new strategies for urban energy planning
- Deployment of a rigorous measurement and verification of energy performance and savings plan
- Market and replication deployment plan, to ensure impact at business level
- Results exploitation strategy suitable to achieve a wider impact



- An ambitious dissemination programme focused on public and professional audiences

#### KEY FACTS

**Start date:** July 2013  
**Duration:** 48 months  
**Total budget (€):** 14.8 million  
**Website:** www.r2cities.eu  
**Coordinator:** Fundación CARTIF, Spain.  
**Partners:** Belgium: youris.com. Germany: Steinbeis. Italy: ABB, D'Appolonia, Genova Municipality, Officinae Verdi, Università di Genova. Spain: Acciona, Onyx Solar Energy, Sociedad Municipal VIVA. Turkey: Energy Institute Istanbul, Kartal Municipality, Eziç, ODE. UK: Exergy.

#### EXPECTED IMPACT

- 3 demonstrators in total (Spain, Italy and Turkey).
- 60% reduction in energy use and 2.1 Mt per year CO<sub>2</sub> savings
- 57,000m<sup>2</sup> renovated surface area
- Estimated 860 dwellings involved and over 25,000 end users engaged
- €5.9 million investment from project partners
- 200 people trained
- 31% of project partners are SMEs

# ZenN

## Nearly zero-energy neighbourhoods

ZenN aims to implement nearly Zero Energy Building Renovation (nZEBR) actions at a neighbourhood scale throughout Europe, through substantial improvements in all relevant aspects of the process: technological, social and financial. The project will provide best practice cases, improved results validation and monitoring procedures, as well as guidelines and training material for all relevant stakeholders.

### Overview

Large scale implementation of nZEBR is hindered by a diverse set of technological, financial and management barriers. The ZenN project was conceived with the objective of developing new perspectives on the holistic approach needed to overcome these difficulties, thus maximising the impact of very low energy renovation of buildings in Europe.

Energy retrofitting at the urban scale has the potential of introducing new technologies, taking advantage of economies of scale, simplifying management procedures, and achieving overall better results. ZenN's main objectives are aligned with this challenge, and will contribute to a large scale implementation of nZEBR actions across the European residential building stock. Some of these objectives are:

- Harmonising the concept of nZEBR
- Demonstrating that the nZEBR vision is possible as well as technically, economically and socially feasible
- Identifying new business and management models that facilitate the replication of the demonstrators
- Ultimately, raising awareness in citizens and public authorities on the relevance and advantages of nZEBR



### KEY FACTS

**Start date:** March 2013  
**Duration:** 48 months  
**Total budget (€):** 15.7 million  
**Website:** [www.zenn-fp7.eu](http://www.zenn-fp7.eu)  
**Coordinator:** Tecnalia research & Innovation, Spain  
**Partners:** France: CEA, Ville de Grenoble. Norway: NTNU, Oslo, Sintef. Poland: ASM. Spain: Ayuntamiento de Eibar, Debegesa, Eusko Jauriaritza / Gobierno Vasco. Sweden: IVL, Malmö.

### EXPECTED IMPACT

- 6 demonstrators in total (France, Norway, Spain and Sweden)
- 58% reduction in energy use
- 107,000m<sup>2</sup> renovated surface area
- Over 3,000 end users engaged
- Estimated 80,000 people reached by dissemination activity
- €31.2 million investment from project
- 3,100 people expected to be trained

# 3ENCULT

## Efficient energy for EU cultural heritage

3ENCULT bridges the gap between the conservation of historic buildings and climate protection. Historic buildings are the trademark of numerous European towns and will only survive if maintained as a living space. Energy efficient retrofit is important both for improving the comfort and reducing energy demand (in terms of money and in terms of resources) and for structural protection in heritage buildings.

### Overview

3ENCULT demonstrates that a consistent reduction in energy demand – by a factor of four to ten – is also achievable in historic buildings respecting their heritage value, if a multi-disciplinary approach guarantees the implementation of high quality interventions targeted and adapted to the specific case.

Including all stakeholders in the energy retrofit of a historic building is therefore a core principle of the project. This multidisciplinary exchange starts with a comprehensive diagnosis, supports the design and includes monitoring and control. There is no such thing as a single solution given that each historic building is unique. Instead, the project will propose a pool of solutions and guidance on choosing the appropriate one for the specific building. Starting with an analysis of the challenge and needs for a comprehensive diagnosis, the project investigates technical solutions for energy enhancement in addition to smart monitoring and control. Industry partners demonstrate the developed solutions, while case studies give stimulus for solution development and feedback. 3ENCULT will provide:

- A handbook with design guidelines and a pool of technical solutions for planners
- New or enhanced products (insulation, windows, lighting, ventilation, solar integration, wireless monitoring and building management systems (BMS))

- Guides for and involvement of local governments
- Position papers and support for policy and standards (EPBD, CEN TC346)

Channels for dissemination include the website, presentations at conferences, fairs, publications, workshops, study tours and video news releases.

A reduction by a factor of four on energy demand of the 26% of EU building stock dating before 1945 would result in a saving of over 180 Mt CO<sub>2</sub> (3.6% of EU27 emissions in 1990) improved living conditions and quality management in historic urban areas.

### Key Achievements

To date, the highly energy efficient conservation-compatible window has been installed (CS1/IT); capillary active internal insulation is under investigation (CS6/DE); a low impact ventilation system based on the active overflow principle is being tested (CS5/AT); wireless sensor networks have been demonstrated (CS3/IT) along with the first version of a dedicated BMS system (CS7/ES); comprehensive diagnosis has been documented at CS2/IT for which an LED-based wall-washer for conservation-compatible, high-quality and low-impact lighting was developed. A virtual library based on a community in [www.buildup.eu](http://www.buildup.eu) has been prepared and the conservation-established “Roombook” has been integrated with energy aspects.



### KEY FACTS

**Start date:** October 2010

**Duration:** 42 months

**Total budget (€):** 6.6 million

**Website:** [www.3encult.eu](http://www.3encult.eu)

**Coordinator:** EURAC research, Italy

**Partners:** Austria: Bartenbach Lichtlabor, University of Innsbruck. Belgium: REHVA, youris.com. Czech Republic: ATREA. Denmark: Royal Danish Academy of Fine Arts. France: Menuiserie André. Germany: ICLEI, IDK, Passivhaus Institut, Remmers, Technical University of Dresden, University of Stuttgart. Italy: Artemis, Municipality of Bologna, University of Bologna. Netherlands: TNO. Spain: CARTIF, Grupo Unisolar. UK: ARUP.

### EXPECTED IMPACT

- 11 demonstrators in total
- 40-50% reduction in energy use
- 8 local case study teams engaged
- Estimated 21,500 people reached by dissemination activity
- €1.65 million investment from project partners
- 500 people trained
- 43% of project partners are SMEs
- 7 technologies may be taken to market
- 7 patents may be applied for



This typical alpine “Strickbau” is being retrofitted within 3ENCULT

# EFFESUS

## Overview

Europe can become the leader in CO<sub>2</sub> emission reductions by applying innovative solutions to its cultural heritage buildings. EFFESUS will therefore develop new technologies, produce a software tool to inform decisions on improvement measures, provide training and awareness activities and demonstrate its project results in real case studies for seven historic urban districts.

The project will ensure that any technical and non-technical barriers preventing the implementation of the results are overcome. The project will engage a large audience so that the research results can be widely disseminated and exploited throughout Europe. The main output of EFFESUS will be the Decision Support System, a software tool to help make informed decisions about improvement measures suitable for historic urban districts. This tool will help prioritise improvement measures

## Energy efficiency for EU historic districts' sustainability

EFFESUS researches the energy efficiency and sustainability of European historic urban districts and investigates measures and tools that make significant improvements while protecting heritage values. Historic urban districts are an integral part of the European cultural identity and heritage. Improving their energy efficiency will help to protect this heritage for future generations.

to achieve significant energy efficiency improvements and carbon emission reductions.

EFFESUS will also support the development of technologies suitable for use within historic urban districts. The tool and technologies developed will be validated in case studies to demonstrate their applicability and sustainability.



### KEY FACTS

**Start date:** September 2012  
**Duration:** 48 months  
**Total budget (€):** 6.7 million  
**Website:** [www.fffesus.eu](http://www.fffesus.eu)  
**Coordinator:** Technalia, Spain  
**Partners:** France: GOUAS. Germany: Fraunhofer, University of Stuttgart. Greece: AMS, I2S. Hungary: HOR-BER. Ireland: DWE. Italy: CNR- ISAC, D'Appolonia, Eurac research, RED. Netherlands: Bofimex. Norway: NTNU, Snekkeriet. Portugal: Active Aerogels. Spain: Acciona, Consorcio Santiago. Sweden: Uppsala University. Turkey: SAMPAS. UK: APG, Dennis Rodwell, Historic Scotland.

### EXPECTED IMPACT

- 7 demonstrators in total (Germany, Hungary, Italy, UK, Turkey, Spain and Sweden)
- Estimated 25% reduction in energy use
- 400m<sup>2</sup> of renovated surface area
- 9 dwellings involved
- 3500 people reached by dissemination activity
- Estimated 4% return on investment
- €1.8 million investment from project partners
- Key training actions: Training courses for students and professional training
- 52% of project partners are SMEs
- 8 technologies may be taken to market
- 2 patents may be applied for

# BEEM-UP

## Building energy efficiency for massive market uptake

BEEM-UP aims to demonstrate the economic, social and technical feasibility of retrofitting to drastically reduce energy consumption in existing buildings while also laying the ground for market uptake. The project involves key expertise to implement and demonstrate innovative building and energy management approaches. It improves energy efficiency in existing buildings, obtaining better indoor comfort conditions.

### Overview

One of the most cost effective measures to transform Europe into a low carbon economy lies in addressing existing residential building stock. BEEM-UP brings a strong consortium of complementary backgrounds and expertise to demonstrate the technical, social and economic feasibility of energy efficient retrofitting in existing residential buildings. BEEM-UP takes an integral approach to overcome barriers through three ambitious retrofitting projects located in Sweden, the Netherlands and France. The project aims to retrofit some 340 dwellings with an average net energy reduction of 75%.

The overall objective of the project is to develop and demonstrate cost-effective and high performance renovation of existing residential buildings, with a drastic reduction of energy consumption, while ensuring a comfortable and healthy living environment.

Some expected scientific and technical objectives of the BEEM-UP project are:

- Define, implement and enhance an integral global approach to energy efficient retrofitting
- Optimise advanced insulation and energy management solutions for cost-efficient application
- Provide decision support tools to assess optimal investment across the housing stock
- Set the basis for large scale replication across Europe

- Increase stakeholder's capacity to meet the requirements of European building policies

The second half of the project will focus on exploitation and dissemination roll out and finishing retrofitting works.

### Key Achievements

A common methodology has been developed to optimise retrofitting scenarios considering ecological, economic and social indicators. Six phases have to be implemented to get optimal scenario selection.

One of our demonstrators is finished and the others are progressing:

- France: 87 dwellings, next to Montparnasse Train Station (Paris). Works started June 2013 and will finish in June 2014. Expected savings 83% energy demand reduction.
- The Netherlands: 108 dwellings in Delft. Envelope works already finished. HVAC systems and tenant dialogue on-going. Demand reduction is from 65 to 76%, depending on tenant's choices.
- Sweden: 129 dwellings in Älingsås. 42 dwellings are finished, 21 under construction and 66 to go, Passive House Standards will bring 76.5% average demand reduction.

Tenant involvement strategies are being deployed, with the goal of finding out what level of tenant involvement is practical and affordable in renovation projects.



### KEY FACTS

**Start date:** January 2011

**Duration:** 48 months

**Total budget (€):** 7.6 million

**Website:** www.beem-up.eu

**Coordinator:** Acciona, Spain

**Partners:** France: ICF Novedis, NOBATEK. Germany: BASF, LUWOCO. Netherlands: Dura Vermeer, ENECO, Maastricht University, OTB, Woonbron. Portugal: ISA. Spain: Bax and Willems, ITA, Macpuarsa, Solintel. Sweden: AHEM, SKANSKA, SP, Chalmers University. Switzerland: ETH Zurich, SIEMENS.

### EXPECTED IMPACT

- 3 demonstrators in total (France, Sweden and the Netherlands)
- Estimated 78% reduction in energy use
- 28,865m<sup>2</sup> surface area renovated
- 324 dwellings involved
- Estimated 5.8% average return on investment
- €33 million investment from project partners
- 20% of project partners are SMEs
- 1 patent may be applied for



Retrofitted building in Sweden

# E2ReBuild

## Creating added value for existing apartment buildings

E2ReBuild's ambition is to transform the retrofitting construction sector into one defined by innovation, high-end technology, energy efficiency and industrialisation. E2ReBuild implements research and develops new retrofitting solutions in planning, design, technology and construction as well as for operation and use of buildings by tenants and building owners. Results are demonstrated via existing buildings in Finland, Sweden, the Netherlands, France, Germany and the UK.

### Overview

Europe's building industry is characterised at large by on-site production, which may be inefficient with regards to cost and production time. The sector is negatively associated with poor quality as well as unsafe and unhealthy working environments.

An industrial construction process for retrofitting is needed to face the enormous need for reduced energy use and renovation of buildings from the post-war era. Using well-designed, prefabricated elements is one way to radically reduce production time, and possibly the cost of retrofit projects in addition to minimising the social disturbance for tenants.

E2ReBuild is designed to cover innovation in planning, design, technology, construction, operation and use of buildings. The research and development work is closely interlinked with the seven full-scale demonstration building projects that serve as prototypes for the application, evaluation and monitoring of proposed technologies and processes.

Knowledge transfer is central in E2ReBuild as lack of knowledge is identified as one of the most difficult barriers for successful, sustainable retrofitting activities. The tools, methods and processes developed and refined by continuous feedback between research and demonstration will be integrated into

an "Industrial Platform for Energy Efficient Retrofitting" for large-scale market deployment.

The aims of E2ReBuild are to investigate, promote and demonstrate cost effective and advanced energy efficient retrofit strategies and solutions that create added value for existing apartment buildings and encourage end-users to stay and build a dynamic society. Additionally the project aims to create a holistic industrialised process that minimises technical and social disturbances for tenants while facilitating energy efficient operation and use of the buildings including encouraging energy efficient behaviour.

### Key Achievements

Construction of all except one of the demonstration buildings has been completed. The monitoring process has also begun; evaluating energy use in terms of space heating, hot water and building electricity together with thermal comfort, air tightness and user behaviour. Guidelines on preliminaries/surveys, monitoring and off-site production, on-site assembly and logistics have been developed, based on experiences from the E2ReBuild demonstration. An evaluation of the different collaboration models featured in the project has also been established. A questionnaire directed at building users has been developed and dialogues with tenants were held.

## E2ReBuild

### KEY FACTS

**Start date:** January 2011  
**Duration:** 42 months  
**Total budget (€):** 8 million  
**Website:** [www.e2rebuild.eu](http://www.e2rebuild.eu)  
**Coordinator:** NCC AB, Sweden  
**Partners:** Finland: Aalto University, NCC Rakennus Oy, PSOAS. France: Opac38. Germany: Gumpp & Maier, Lichtblau Architekten, GWG München, SchwörerHaus, WBG Augsburg, TUM - Technische Universität München. Netherlands: AlleeWonen, Trecodome. Poland: Mostostal. Sweden: Apartment Bostad Väst, SP Technical Research Institute of Sweden, White arkitekter. Switzerland: Empa, HSLU Hochschule Luzern Technik & Architektur. UK: Gallions Housing Association.

### EXPECTED IMPACT

- 7 demonstrators in total (Finland, Sweden, Netherlands, France, Germany and the UK)
- 54 – 76% reduction in energy use
- 27,994m<sup>2</sup> surface area renovated
- 341 dwellings involved
- 52,000 people reached by dissemination activity
- Estimate of return on investment varies with type of real estate; the private sector has a higher ROI than the social housing sector
- €3,3 million investment from project partners
- 24% of project partners are SMEs
- Estimated 8 technologies may be taken to market



A photo-montage of the exterior of the E2ReBuild demonstration building Virkakatu 8 A-B in Oulu, Finland

# School of the Future

## Towards zero emissions with high performance indoor environment

The aim of the project is to design, realise and communicate good examples of future high performance buildings. Both the energy and indoor environmental performance of the demonstration buildings in different European climates will be greatly improved. This will be achieved via holistic retrofits of the building envelope and service systems including the integration of renewables and management systems.

### Overview

The societal values strongly formed by public models are also true for buildings. When public authorities have a good approach, it is easier to gain people's attention to exhibit the need for change, significantly increasing the quantity and quality of energy efficient retrofits in Europe. It is therefore important to demonstrate exemplary solutions at frequently used public buildings such as schools. Europe is dependent on having high quality education spaces for its future generations. The use of public buildings as frontrunners will help increase the market penetration of high performance retrofit approaches. The 100% carbon free school building has to become the standard of the future.

The objectives of the project include the development of people's consciousness to save energy by exemplary realisations of highly energy efficient retrofit projects on school buildings. These will lead the way to a carbon-free operation of school buildings while improving the indoor environment. This approach will be promoted as the school of the future. The project will also demonstrate that energy savings can be achieved with limited additional costs (< 100 €/m<sup>2</sup>) to motivate other actors in the sector to multiply the concepts. Reliable information on energy saving potentials and costs will cut back on reservations against innovative energy saving retrofit concepts. National and European benchmarking systems will be developed including an estimation of

the potential for innovative, cost-efficient energy retrofit strategies.

### Key Achievements

The project will result in 27 deliverables including:

- Four retrofitted school buildings with the total energy use reduced by a factor of 3, the heating energy use reduced by more than 75% and an improved indoor environment quality
- Up-to-date guidelines and tools for energy efficient, high quality indoor environment renovations of school buildings
- Training material for facility managers, teachers and pupils

At the end of June 2013 the following project outcomes were available on the website:

- A summary report and database of international knowledge concerning energy efficient school buildings and high indoor comfort
- A discussion platform on the EU portal BUILD UP (<http://www.buildup.eu/communities/schoolfuture>)
- A report on the assessment of the indoor environment including an occupant questionnaire and measurement instructions
- A report documenting the design phase of the 4 demonstration buildings
- Building diaries showing the progress of the retrofit constructions
- News, press articles, papers and contributions to technical journals



### KEY FACTS

**Start date:** February 2011

**Duration:** 60 months

**Total budget (€):** 4.9 million

**Website:** [www.school-of-the-future.eu](http://www.school-of-the-future.eu), [www.buildup.eu/communities/schoolfuture](http://www.buildup.eu/communities/schoolfuture)

**Coordinator:** Fraunhofer Institute for Building Physics, Germany

**Partners:** Denmark: Cenergia Energy Consultants, Aalborg Universitet – SBI, Ballerup Kommune, Saint-Gobain Isover, Schneider Electric Building Denmark AS. Germany: Fraunhofer Institute for Building Physics, Landeshauptstadt Stuttgart. Italy: ENEA, Comune di Cesena, Aldes. Norway: Stiftelsen SINTEF, Drammen Eiendom, Glass og Fasadeforeningen.

### EXPECTED IMPACT

- 4 demonstrators in total (Germany, Italy, Denmark and Norway)
- 66% reduction in total delivered energy and 75% reduction in heating energy use
- 25,880m<sup>2</sup> surface area renovated
- 4 schools involved and more than 2000 end users engaged
- €1.5 investment from project partners
- Key training actions: Training material and exemplary training seminar for facility managers, teachers and pupils and extension of a calculation tool to assess the energy efficiency of school buildings which will be used by pupils
- 8% of project partners are SMEs
- 15 technologies may be taken to market

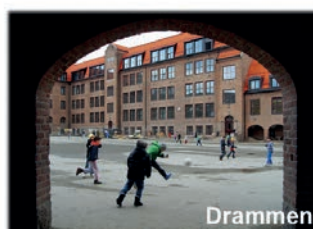

Four demonstration school buildings to be retrofitted in a highly energy efficient way within the School of the Future project

## Cost-Effective

## Resource and cost-effective integration of renewables in existing high-rise buildings

In high-rise buildings high fractions of energy demand can only be met with renewable energy sources when the façade is used for energy conversion in addition to the roof. Therefore, the main focus of this project is to convert facades of existing high-rise buildings into multifunctional, energy gaining components.

### Overview

In 2009 the regulatory framework and business environment for the construction sector changed significantly in order to reduce carbon emissions of existing and new buildings. Europe has identified future goals of net-zero-energy buildings with new buildings required to be net-zero after 2020 and some public buildings aiming for 2018. Several national Governments (e.g. Germany) have taken the challenge further by trying to achieve a net-zero primary energy balance for the complete building stock by 2050. In order to reach these goals two things have to be done:

- The efficiency needs to be increased, especially in terms of existing buildings
- The remaining energy demand needs to be covered by renewable sources

The two most challenging aspects resulting from these goals are:

- The large number of buildings which need to be renovated. This therefore requires investments and more construction labour than is currently available
- In many cases, current processes and building components are not ready for widespread and cost-effective implementation of energy-harvesting functionalities in the building skin

A fundamental transformation of the construction sector is necessary in order to streamline the fragmented responsibilities and to develop business models which are attractive to third-party financing. This "great transition" implies

the necessity of dramatic changes in the near future. These changes cannot be avoided and an increase in activity within the building sector, especially in the case of existing buildings is expected.

The main project objectives include new façade components, business models, technical concepts and demonstration in two pilot buildings.

### Key Achievements

Information has been collected and problems and opportunities identified in existing high-rise buildings in EU25, USA and China. Specifications of various building components with regard to energy consumption reduction goals and user comfort (performance-based) have been defined. Five innovative façade systems have been developed and tested. Three of the façade systems include solar thermal façade collectors, one includes an innovative Building-Integrated-Photovoltaics (BIPV) system and one is a new system for natural ventilation with heat recovery. New integrated techno-economic concepts (business models + technical concepts) including new and existing façade integrated, energy generating components based on renewable energy sources have been developed. Demonstration buildings for the innovative prototypes exist. Additional to the planned building in Spain the project succeeded with an alternative demonstration building in Slovenia.



### KEY FACTS

**Start date:** October 2008

**Duration:** 48 months

**Total budget (€):** 10.7 million

**Website:** [www.cost-effective-renewables.eu](http://www.cost-effective-renewables.eu)

**Coordinator:** Fraunhofer Institut für Solare Energiesysteme ISE, Germany

**Partners:** France: CSTB, EDF. Germany: BSW-Solar, Interpane, Josef Gartner GmbH, Kollektorfabrik GmbH & Co. KG, PSE AG, Sto AG, Universität Stuttgart (LBP). Greece: National and Kapodistrian University of Athens. Italy: D'Appolonia S.p.A., Permasteelisa S.p.a.. Netherlands: Alusta natuurlijke ventilatietechniek BV, BEAR Architecten (Sub-Contractor), TNO. Poland: ASM. Slovenia: Hidria, Slovenian National Building and Civil Engineering Institute ZAG. Spain: Acciona, Fundación Tecnalia. Sweden: NIBE. Switzerland: Emmer Pfenninger Partner AG, IPB GmbH Ingenieurgesellschaft für Energie- & Gebäudetechnik.

### EXPECTED IMPACT

- 4 demonstrators in total (Slovenia and Spain)
- Estimated 150m<sup>2</sup> façade surface renovated
- 2 dwellings involved
- Estimated 750,000 people reached by dissemination activity
- Estimated 70% return on investment
- €3.2 million investment from project partners
- Key training actions: 15 dissemination activities on trade fairs and exhibitions. Two training sessions were organised by CSTB. Lecture about Cost Effective held in Athens
- 19 people trained
- 7% of project partners are SMEs
- 5 technologies may be taken to market
- 2 patents applied for

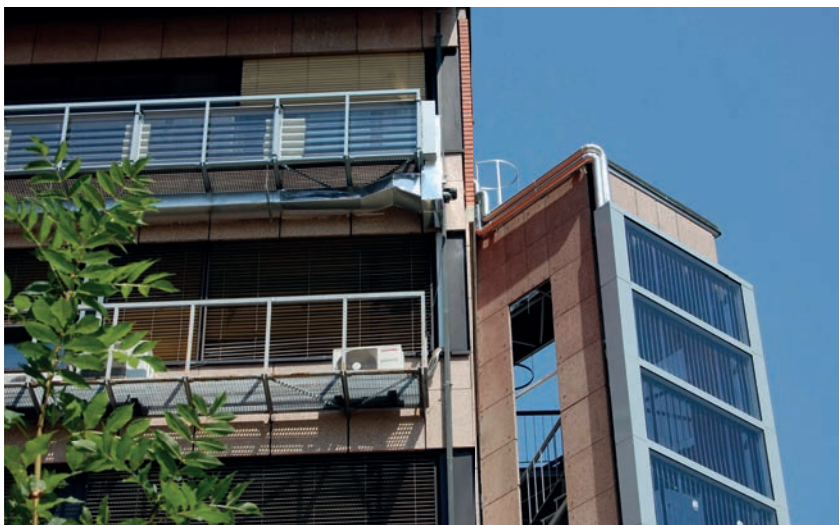

Pilot installations in Slovenia (picture: ZAG)

## Envelope approach to improve sustainability and energy efficiency in existing multi-story multi-owner residential buildings

More than half of European buildings were constructed when energy efficiency was of little or no consideration. Ten million of these are multi-story residential buildings with multiple occupants. EASEE proposes a new approach to achieve energy efficiency of this building stock with a strong impact in terms of energy and economic savings, boosting the application of sustainable and energy efficient solutions.

### Overview

In line with current European energy efficiency legislations, more attention is being paid to the energy behaviour of existing buildings. However, in Europe the biggest share of existing stock was built before the introduction of energy efficiency into national building codes. These buildings now require an appropriate envelope refurbishment to fulfil current regulatory standards. The EASEE project aims to develop a toolkit for energy efficient envelope retrofitting of existing multi-story and multi-owner buildings (with a particular focus on residential buildings with cavity walls built before the 70's). This will reduce energy demand, minimise impact on occupants while also preserving the original appearance of the building's facade.

Focus will be on the three main envelope components that influence a building's energy performance - namely the outer facade, cavity walls and interior envelope - by developing innovative and easy to implement solutions.

EASEE's main expected outcomes are:

- Innovative pre-fabricated panels with built-in insulation, reproducing the original aesthetics of the facade
- A new range of insulating inorganic materials for the cavity wall based on natural and synthetic perlite

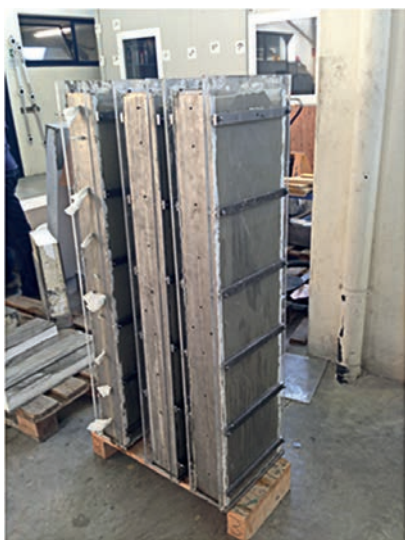

Lab-scale prototypes of prefabricated insulating panels developed within the EASEE project

- Innovative insulating solutions for the internal walls based on a combination of technical textiles, coatings and high performance plasters
- A Retrofitting Planner, providing specifications for component manufacturing as well as information on the best combination of retrofitting solutions for the specific building in terms of initial investment, expected savings and performances

EASEE's main benefits are:

- Minimum impact on occupants (normally negative)
- Payback on investment below 7 years (retrofitting costs up to a maximum of 120 euro/m<sup>2</sup>)
- Creation of business opportunities and skilled jobs

### Key Achievements

The EASEE project was launched in March 2012. Initially the project's systemic approach and new value proposition for building retrofitting was defined. Activities were then carried out to develop conceptual designs for three envelope retrofitting solutions while also providing related lab-scale prototypes on which preliminary characterisation tests were performed.

The initialisation of the Retrofitting Planner was also developed in addition to a preliminary design of both the mould for the exterior panels and their anchoring systems and joints.



### KEY FACTS

**Start date:** March 2012

**Duration:** 48 months

**Total budget (€):** 7.6 million

**Website:** [www.easee-project.eu](http://www.easee-project.eu)

**Coordinator:** D'Appolonia S.p.A, Italy

**Partners:** Belgium: Building Performance Institute of Europe (BPIE). Germany: Schwenk GmbH. Greece: National Technical University of Athens (NTUA), S&B Industrial Minerals. Italy: Consortium of European Small and Middle-Sized Anchors Producers (ECAP), Halfen srl, Imprima Costruzioni srl, Magnetti Building Solutions, Politecnico di Milano, STAM srl. Poland: CIM-MES Project sp zoo, Pre-Fasada, Ridan sp zoo. Spain: Ancodarq SL. Switzerland: EMPA (Swiss Federal Laboratories for material science and technology). UK: IES Integrated Environmental Solutions.

### EXPECTED IMPACT

- 4 demonstrators in total (Italy, Spain, Poland, and Czech Republic)
- 22 dwellings involved
- Estimated 300 people reached by dissemination activity
- Estimated 7 year payback on investment
- €2.5 million investment from project partners
- Key training actions: Training of SMEs in the construction sector responsible for mounting and installation of new solutions developed within the project
- 47% of project partners are SMEs
- 6 technologies may be taken to market

# MEEFS Retrofitting

## Multifunctional energy efficient façade system for building retrofitting

MEEFS aims to develop, evaluate and demonstrate an innovative multifunctional façade system for drastically improving energy efficiency of retrofitting in the residential building sector across Europe. The team is working collaboratively on the façade development (architecture, energy management system, installation, and structural material), façade evaluation (of energy efficiency, new composite material life cycle and fire resistance) and façade demonstration using a building in Spain.

### Overview

Europe's building stock comprises approximately 160 million buildings, which are responsible for 40% of Europe's total primary energy consumption and 30% of greenhouse gas emissions. Over 80% of these buildings are 10 years or older, thus transformation is crucial in order to achieve Europe's 2020 objectives. The key to greater energy efficiency lies in residential buildings which represent about 80% of the total building stock and 63% of the final energy consumption. Current retrofitting practices of residential buildings pose a variety of challenges to the construction sector and leave considerable room for improvement. Most available solutions only offer thermal insulation, have low aesthetic quality and are uniform in terms of applicability to different types of buildings and façade orientations. Climate and energy needs are not properly considered and they make little use of innovative passive and active technologies.

Final results of the MEEFS project should bring a flexible solution; adapted to different architectonic configurations and typologies, modular as a system that combines different technological energy efficient solutions in standardised Technological Units (TUs) and façade structural elements (panels and modules) manufactured using composite materials to ensure lightness (FRP - Fibre Reinforced Polymer).

Energy efficient structural panels and modules integrated within the façade will include technologies (TUs) that reduce the energy demand of the building or supply energy by means of renewable energy systems. Two new energy efficient modules are being developed: Advanced Passive Solar Protector and Energy Absorption Auto Mobile unit, and Advanced Passive Solar Collector and Ventilation Module.

### Key Achievements

During 2012, an analysis of the residential building typologies and legal aspects in EU countries led to the development of the standard façade system module dimensioning and definition. Façade TUs for the demonstration building and their distribution on the façade have been selected. Unit configuration was established to achieve the best possible annual energy performance balance of heating and cooling loads for different climate locations. The design of the two energy efficient modules was completed. An energy management system and nodal network topology was designed and respective communication layers chosen. Hardware for central management was selected and a single module node designed and prototyped. Progress has been made in identifying a suitable composite material and manufacturing process. The solution will be evaluated at a demonstrator building in Spain.



### KEY FACTS

**Start date:** January 2012  
**Duration:** 48 months  
**Total budget (€):** 9.9 million  
**Website:** [www.meefs-retrofitting.eu](http://www.meefs-retrofitting.eu)  
**Coordinator:** Acciona Infraestructuras, Spain  
**Partners:** Belgium: Greenovatel Europe. Finland: Teknologian Tutkimuskeskus VTT. France: CQFD Composites SARL, TBC Générateurs D'innovation. Germany: Fraunhofer-Gesellschaft zur Foerderung der angewandten Forschung E.V. Greece: G.K. Rizakos – ABETE, National Technical University of Athens. Israel: Technion – Israel Institute of Technology. Italy: AntWorks SRL, Vipiemme Solar SRL. Poland: SKA Polska Sp. z o.o., TPF Spółka z ograniczona odpowiedzialnoscia - E&L Architects. Spain: Advanced Simulation Technologies - AST, Consejería de Fomento - Junta de Extremadura, Fundación Tecnalia Research & Innovation.

### EXPECTED IMPACT

- 1 demonstrator in total (Spain)
- Estimated 40% reduction in energy use and 7.5t CO<sub>2</sub> savings per year
- 1000m<sup>2</sup> of façade area renovated
- Estimated 40 dwellings involved and 200 end users engaged
- Estimated 69% of project partners are SMEs
- At least 4 technologies may be taken to market
- At least 4 patents may be applied for



MEEFS façade proposed for demonstration building in Merida, Spain

# Buildsmart

## Energy efficient solutions ready for market

Eleven large-scale residential and non-residential buildings are to be constructed across various climate zones in Europe using innovative and cost-effective techniques and methods. New technologies displaying live energy use data will be used to educate homeowners, employees and the public as a means to influence their behavioural patterns. In addition, the possibility of mainstreaming the above will be studied.

### Overview

Buildsmart looks at a number of very low-energy and non-residential buildings in three countries with varying climates, cultural aspects and technologies. These varied conditions provide a broad overview of other areas within the EU and will therefore facilitate deployment and exploitation of outcomes and developments as the project progresses. The objective of Buildsmart is to demonstrate and mainstream innovative and cost effective techniques and methods for constructing very low energy buildings in various climates. Residential and non-residential new builds in Sweden, Ireland and Spain will be used as demonstrators. New incentives will be developed and implemented to increase the involvement of inhabitants, highlighting how they can benefit from lower energy costs and an improved environment. Total gross floor space of the buildings will be 81,300m<sup>2</sup>. Demonstrator buildings types are varied to represent a broad range:

- Sweden: In Malmö, a hotel and a residential building located in the concert, congress and hotel area of the city centre will be erected and showcased along with a municipal nursery school and a number of residential and non-residential buildings in the Hyllie area

- Ireland: In Dublin, Dominick Street Lower Development, a mix of residential and commercial units will be erected and showcased
- Basque Country: In the Portugalete municipality of Greater Bilbao, three residential blocks of five floors will be constructed

All actions implemented will be analysed from a systems perspective, taking into consideration the whole energy system. Primary energy needs for different technology choices as well as life cycle costs will be calculated.

### Key Achievements

The participating demonstration buildings are at different phases, some being in the design phase while others under construction. The project's running time will be extended as unstable market conditions have postponed some of the initial construction processes.

The large scale demonstration buildings are characterised by the following innovative techniques:

- Energy efficient building envelopes with high air tightness and low energy losses
- Energy efficient installations creating a minimised energy use
- Techniques for minimising cooling needs such as efficient windows and shading equipment

**BUILDSMART**  
Energy efficient solutions ready for market

### KEY FACTS

**Start date:** December 2011  
**Duration:** 45 months  
**Total budget (€):** 8.6 million  
**Website:** [www.buildsmart-energy.eu](http://www.buildsmart-energy.eu)  
**Coordinator:** City of Malmö, Sweden  
**Partners:** Ireland: CODEMA, Dublin City Council. Spain: Basque Government, FCC Construcción, Tecnalia. Sweden: Ikano Bostad, IVL – Svenska Miljöinstitutet, NCC Boende, PEAB Sverige, Roth Fastigheter, Skanska.

### EXPECTED IMPACT

- 11 demonstrators in total (Sweden, Ireland and Spain)
- 81,300m<sup>2</sup> new build efficient area
- Anticipated impact over the next 5 years: the technologies and methods demonstrated in Buildsmart should be considered as potential options for other building projects in a range of countries



The new hotel building in downtown Malmö is one of the demonstrators

# DIRECTION

## Demonstration at European level of innovative and replicable effective solutions for low energy new buildings

DIRECTION aims to create a framework for the demonstration and dissemination of innovative and cost-effective energy efficiency technologies for the achievement of very low energy new buildings. Three new builds will be used as pilot studies. Each will be deployed with a set of innovative measures, constructive elements for energy optimisation, highly efficient equipment and advanced energy management.

### Overview

How can the overall energy efficiency of a building be enhanced to achieve a consumption level of primary energy lower than 60 kWh per m<sup>2</sup> per year? The DIRECTION project was launched to try and find answers to this question. During the course of this four year project, building and construction engineers, architects, energy researchers, IT specialists and public authorities will work together to show how such an ambitious goal can be reached.

Based on the analysis of suitable energy efficiency technologies and their technical and economic viability, demonstration activity will be deployed in three new buildings located in Valladolid (Spain), Bolzano (Italy) and Munich (Germany). Each will have installed a set of innovative measures such as constructive elements for energy optimisation, highly efficient energy equipment and advanced energy management. Energy consumption reductions over 50% and CO<sub>2</sub> emission reductions over 60% are expected.

DIRECTION will deploy several phases:

- Energy efficiency measures analysis
- Demonstration buildings construction
- Monitoring and energy performance and savings assessing plan, including simulation and modelling tasks
- Systems and facilities commissioning and testing

- One year of monitoring in operation
- Implementation of dissemination plan

The work plan reflects this phase through partial dedication to the demonstration strategy and partial dedication to the development of a methodology for the energy performance assessment, data acquisition needs, reporting period plan (for validation phase) and built models. In parallel DIRECTION will deploy an ambitious dissemination plan implementing a multichannel approach. Local, national and European stakeholders including public authorities, users and citizens at large will be kept up-to-date about the progress and the outcomes of the demonstration.

### Key Achievements

DIRECTION will produce a total of 55 public deliverables covering all aspects mentioned at the general or specific level including BIM, metering and monitoring projects, control strategies, BMS and performance analysis for both envelope and systems. On completion, a best practice book will be created. The initial three semesters have seen the project team generate a total of 21 deliverables including the evaluation planning for the buildings, first analysis of the solutions selected for the demonstrations and monitoring and metering projects for the two finished buildings.



### KEY FACTS

**Start date:** January 2012  
**Duration:** 48 months  
**Total budget (€):** 6.95 million  
**Website:** [www.direction-fp7.eu](http://www.direction-fp7.eu)  
**Coordinator:** Fundación CARTIF. Spain.  
**Partners:** Belgium: youris.com G.E.I.E.  
Germany: Domagk Gewerbepark, FACIT GmbH und Co. KG, Fraunhofer Institute for Building Physics. Italy: Claudio Lucchin & architetti associate, Enginsoft SpA, EURAC, Province of Bolzano. Spain: 1A Ingenieros, Dragados.

### EXPECTED IMPACT

- 3 demonstrators in total (Spain, Germany and Italy)
- 20% reduction in energy use and 63t per year CO<sub>2</sub> savings per building
- 26,361m<sup>2</sup> new build efficient area
- Estimated €7 million investment from project partners
- Key training actions: workshops and creation of material for professional training
- Estimated 40% of project partners are SMEs



**Munich**  
NuOffice

**Boecillo - Valladolid**  
CARTIF III

**Bolzano**  
Black Monolith



DIRECTION demonstration new buildings

# NEED4B

## New energy efficient demonstration for buildings

NEED4B develops an open and easily replicable methodology for designing, constructing and operating low energy new buildings, aimed at a large market uptake. The NEED4B methodology is validated and refined by the construction of 27,000m<sup>2</sup> spread among five demonstration sites covering different climatic zones, building types and uses. This ensures reliability of results and guarantees impact in the construction sector.

### Overview

The building sector is the highest energy consumer in the EU. In order to drastically reduce its energy consumption and associated GHG emissions, the European Directive 2010/31/UE established that all new builds must reach near-zero energy consumption levels by 2020.

In this context, a strong effort is needed to adopt energy efficiency advances and business strategies in new construction projects, as well as associated business strategies that result in large-scale market deployment of E2B. NEED4B aims at demonstrating the technical, social and economic feasibility of this challenge.

The overall objective of the project is to develop a new replicable methodological approach for designing, constructing and operating low energy new builds. This methodology will be validated and enriched by the experience gathered in several demonstration buildings to be constructed in five European countries. The variety of typologies and uses as well as their location in different climates will allow project results to be broadly applicable across Europe.

All buildings have a common target of achieving an energy consumption lower than 60 kWh/m<sup>2</sup> year. This target will be possible thanks to the selection and integration of the most suitable set of innovative and cost-effective energy efficient solutions and technologies for each of the buildings. NEED4B will deliver recommendations and guidelines adapted for different stakeholders.

An ambitious dissemination plan has been created, including demonstrators that ensure the project's visibility and impact within the European construction sector.

A monitoring programme lasting 2 and a half years will be deployed to eventually evaluate the benefits and impacts achieved. Exploitation plans will be developed to obtain new business models that overcome current market barriers.

### Key Achievements

- For every demonstrator:
  - Assessment of the influence of European, national, local requirements and standards
  - Definition of energy targets and labels to be achieved
  - Early identification and involvement of related stakeholders
- Definition of information exchange standards for BIM tools to be employed
- Development of the NEED4B methodology approach, based on other existing methods, including Integrated Project Delivery (IPD), Building Information Modelling (BIM) and Life Cycle Assessments (LCs).
- Release of preliminary guidelines to keep consumption under 60 kWh/m<sup>2</sup>/year addressing: structure and envelope, HVAC, RES integration, water and waste management, control ICT systems
- Finalising the design projects according to the results from simulations



### KEY FACTS

**Start date:** February 2012

**Duration:** 72 months

**Total budget (€):** 9.4 million

**Website:** [www.need4b.eu](http://www.need4b.eu)

**Coordinator:** CIRCE Foundation, Spain.

**Partners:** Belgium: Format D2, Intesa SanPaolo Eurodesk, M5, Université de Mons, Vue Sur Mons. Italy: D'Appolonia, Imprima Costruzioni. Spain: Acciona Infraestructuras, Ingeniería y Control Electrónico, Universidad de Zaragoza. Sweden: Derome, SP Technical Research Institute of Sweden. Turkey: BG Mimarlik, Fiba Holding, Özyeğin University.

### EXPECTED IMPACT

- 5 demonstrators in total (Belgium, Italy, Spain, Sweden and Turkey)
- 65% reduction in energy use and 800t CO<sub>2</sub> savings per year (in pilot studies)
- 26,195m<sup>2</sup> new build efficient area
- 52 dwellings involved and 2,300 end users engaged
- 25,000 people reached by dissemination activity
- 10 year payback on investment
- €191 million investment from project partners
- 500 people trained
- 38% of project partners are SMEs
- 1 technology may be taken to market

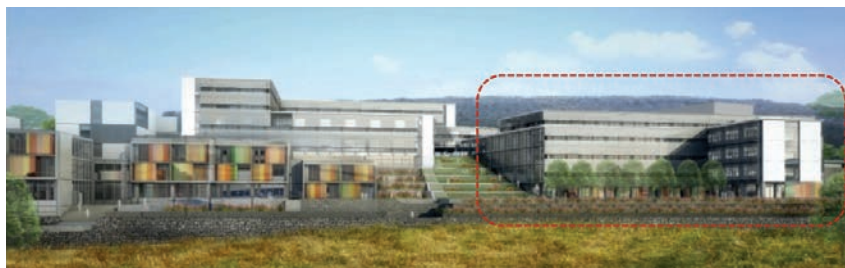

The Turkish demonstration site is situated in the Özyeğin University Campus (Istanbul). The building has a total surface of 17,756 m<sup>2</sup> and will host the School of English Language Instruction

# NEXT-Buildings

## Next zero energy buildings at lowest cost using competitive sustainable technology

The NEXT-Buildings project focuses on the demonstration of low-energy, affordable buildings. The ambition is net-zero carbon/energy or better and will pave the way for large-scale implementation of energy neutral buildings and neighbourhoods as foreseen in the Energy Performance of Buildings Directive (EPBD). The pilot studies are running more than five years ahead of the EU goal to have energy-neutral new build dwellings by the start of 2019.

### Overview

This project is based on selected successful cities and actors in the CONCERTO programme that want to demonstrate the next generation of low energy buildings. While including buildings, these also cover active components in overall energy systems including smart technologies and ICT as well as energy exchange with the overall supply. Solutions will reduce CO<sub>2</sub> at negative or no cost. The common approach is: reduce demand, sustainable heat and use of local renewables for residual demand. The three pilot studies (Amsterdam, Lyon and Helsingborg) have a total gross floor area of about 50,000m<sup>2</sup>. In Amsterdam, the current development is based on the new requirement that all new build areas need to be energy-neutral. In Lyon, the new Hikari building is developed in the successful Confluence area and the Helsingborg building builds on previous successes.

The overall project objective is to demonstrate affordable and well-integrated net zero-energy and active buildings in the urban environment. This means the project will develop new products, elements and technologies offering the possibility to build low-energy dwellings in a more efficient way in terms of energy consumption, costs and replication. Themes of special focus

include dealing with heat recovery and control, inhabitants' feedback, enhanced monitoring and building integration of renewables. Four new products are investigated and developed, ranging from innovative combinations of existing technologies to the development of new technologies.

### Key Achievements

- In Amsterdam, the option chart for energy neutral buildings has been developed. Focus is on collective self-organised development. There has been ample interest in the building lots and land-sell agreements are currently being signed. First construction work for a school has recently started. The local network operator completed a study on the design of the electricity distribution network needed to handle a large quantity of locally produced renewable energy.
- In Lyon, developer Bouygues joined the project. Land sales and building permits are in place.
- In Helsingborg the project had to move from the original site to Kvarteret Isbanan, due to shifting priorities in the city. Initial reports related to the definition of requirements for transmission controllable glazing and dual function PV, have been produced.



### KEY FACTS

**Start date:** January 2012  
**Duration:** 72 months  
**Total budget (€):** 8.4 million  
**Website:** www.next-buildings.com  
**Coordinator:** KEMA Nederland B.V., Netherlands  
**Partners:** Denmark: COWI A/S. France: HESPUL, SPLA Lyon Confluence. Germany: University of Kassel. Netherlands: Gemeente Amsterdam Stadsdeel West, Liander N.V., Vrije Universiteit Amsterdam (IVM). Sweden: BKAB Boende Komfort, Helsingborgshem. Switzerland: Ecole Polytechnique Federale De Lausanne.

### EXPECTED IMPACT

- 3 demonstrators in total (Netherlands, France and Sweden)
- 88% reduction in energy use and 0.003Mt CO<sub>2</sub> savings per year
- 50,000m<sup>2</sup> new build efficient area (m<sup>2</sup>)
- 366 dwellings involved and estimated 970 end users engaged
- 1,500-20,000 people reached by dissemination activity
- 4% return on investment
- €50 million investment from project partners
- Key training actions: training of designers and base organisation
- 15 people trained
- 17% of project partners are SMEs
- 5 technologies may be taken to market



Impression of the Amsterdam Houthaven project site

# HERB

## Overview

The main aim of HERB is to reduce energy consumption in domestic properties by 80% and carbon emissions by 60%, utilising a holistic approach to retrofit and using a combination of technologies. Currently the regulations used to determine what measures are installed during retrofit vary with some being specific (e.g. Wall U-Values) while others are more general (e.g. target building energy consumption). The problem with this is houses retrofitted following these regulations tend to perform differently depending on location and construction. Therefore a more general and flexible approach is required in order to achieve the energy savings aspired to. By combining existing technology utilising building simulation models it is possible to reach an 80% reduction in energy consumption. However it is recognised

## Holistic energy efficient retrofit of buildings

The HERB project aims to develop existing retrofit technologies by solving many of the associated problems. Technical solutions will be developed to resolve issues around the high cost associated with the reduction of energy consumption in existing dwellings by 80%. This will include the development of super-thin insulations, combining ventilation and lighting systems amongst others innovations.

that many practical implications will arise because of this (such as high-thickness insulation). The retrofit innovations developed within the HERB project aim to mitigate these problems while being as cost effective as possible.



KEY FACTS	EXPECTED IMPACT
<p><b>Start date:</b> October 2012</p> <p><b>Duration:</b> 48 months</p> <p><b>Total budget (€):</b> 8.6 million</p> <p><b>Website:</b> www.euroretrofit.com</p> <p><b>Coordinator:</b> University of Nottingham, UK</p> <p><b>Partners:</b> Germany: Stuttgart University of Applied Sciences. Greece: Green Evolution, University of Athens. Italy: Municipality of Bologna, University of Bologna. Netherlands: TNO. Poland: Complex Ltd. Portugal: Almada City Council, Lasting Values. Spain: Onyx Solar. Switzerland: HEIG-VD. Turkey: Izocam. UK: Kingspan Insulation, Leicester Housing Association, The Mark Group, PCM Products Ltd.</p>	<ul style="list-style-type: none"> <li>7 demonstrators in total (Greece, Portugal, Italy, Switzerland, Netherlands, Spain and UK)</li> <li>80% reduction in energy use and 60% reduction in CO<sub>2</sub> emissions</li> <li>3,280m<sup>2</sup> of renovated surface area</li> <li>12 dwellings involved and over 100 end users engaged</li> <li>Over 50,000 people reached by dissemination activity</li> <li>€2.2 million investment from project partners</li> <li>4% of project partners are SMEs</li> <li>7 technologies may be taken to market</li> <li>7 patents may be applied for</li> </ul>

# iNSPiRe

## Overview

In line with the EU's Energy Performance of Buildings Directive recast (EPBD recast, 2010), iNSPiRe will find solutions to reduce the primary energy consumption of existing buildings across Europe to lower than 50 kWh/m<sup>2</sup>/year, by defining a process for renovation and developing energy saving technologies and products that will be placed on the market. The project will develop standardised systemic renovation packages (using envelope renovation, energy generation and energy distribution technologies) that can be applied to residential and office buildings. The packages will be suitable for a variety of climates while ensuring optimum comfort for the building users. In addition, innovative technologies for heating, cooling and ventilation will be designed and developed. As a result, buildings will consume less energy for their heating, cooling and lighting needs

## Development of systemic packages for deep energy renovation of residential and tertiary buildings including envelope and systems

iNSPiRe will tackle the problem of high energy consumption by producing systemic renovation packages that can be applied to both residential and tertiary buildings. The renovation packages developed by iNSPiRe aim to reduce the primary energy consumption of a building to lower than 50 kWh/m<sup>2</sup>/year. Suitable for a variety of climates, these packages will ensure optimum comfort for the building users.

and use renewable energy sources, leading to greater efficiencies in running costs. There will also be cost savings in the renovation process, while the value of the renovated buildings will increase.



KEY FACTS	EXPECTED IMPACT
<p><b>Start date:</b> October 2012</p> <p><b>Duration:</b> 48 months</p> <p><b>Total budget (€):</b> 7.5 million</p> <p><b>Website:</b> www.inspirefp7.com</p> <p><b>Coordinator:</b> EURAC, Italy</p> <p><b>Partners:</b> Austria: Bartenbach LichtLabor GmbH, Siko Solar GmbH, Tripan GmbH, Universitaet Innsbruck. Belgium: Architects' Council of Europe (ACE), International Union of Property Owners. France: CYOLECO. Germany: Fraunhofer Institute for Solar Energy Systems ISE, Gump &amp; Maier GmbH, ICLEI European Secretariat, Ludwigsburger Wohnungsbau GmbH, Vaillant GmbH. Italy: Gruppo Industriale Tosoni, Manens-Tif S.P.A., Università Ca' Foscari. Spain: Acciona, CARTIF, Empresa Municipal de Vivienda y Suelo de Madrid. Sweden: ClimateWell, Solar Energy Research Centre. UK: BSRIA, Insight Publishers.</p>	<ul style="list-style-type: none"> <li>3 demonstrators in total (Germany, Spain and Italy)</li> <li>80% reduction in energy use and 30t per year CO<sub>2</sub> savings</li> <li>800m<sup>2</sup> of residential and 200m<sup>2</sup> of office renovated surface area</li> <li>14 dwellings and 1 office level involved and around 40 end users engaged</li> <li>Estimated 40,000 people reached by dissemination activity</li> <li>€3.5 million investment from project partners</li> <li>Key training actions: Training manuals, workshops, demonstrations of renovated buildings, renovation kit and package guidelines</li> <li>500 people trained</li> <li>38% of project partners are SMEs</li> <li>4 technologies may be taken to market</li> <li>6 patents may be applied for</li> </ul>

# RetroKit

## Overview

Residential buildings constructed between 1945 and 1980, a period in which Europe saw an increase in construction activity following World War II, have the largest energy demand. Most of them now require retrofitting or refurbishing interventions: Europe needs a systemic approach to retrofitting. The RetroKit project aims to develop and demonstrate solutions using three pilot buildings (located in Spain, Germany, and the Netherlands) and multifunctional, modular, low cost and easy to install prefabricated modules to significantly increase the EU retrofitting rate and contribute to EU energy efficiency commitments. RetroKit targets the social, technological, industrial, and economic barriers faced in producing the most efficient retrofit solutions. RetroKit's expected objective will be the development of a retrofit toolbox based on modular and multifunctional prefabricated solutions with integrated

## Toolboxes for systemic retrofitting

RetroKit aims to develop and demonstrate multifunctional, modular, low cost and easy to install prefabricated modules, integrating efficient energy use systems and Resource Efficiency Solutions (RES) for systemic retrofitting of residential buildings. Solutions will target aging multi-family residential buildings that represent more than half of the European building stock and consume between 65% and 80% of the total energy consumptions of EU buildings.

HVAC, electricity, ICT and renewable energy technologies to upgrade residential building envelopes. RetroKit's systemic approach will streamline the value chain, thus enabling customised mass production, industrial scale-up and efficient construction processes for manufacturers, integrators, installers and contractors.



### KEY FACTS

**Start date:** September 2012  
**Duration:** 48 months  
**Total budget (€):** 10 million  
**Website:** [www.retrokitproject.eu](http://www.retrokitproject.eu)  
**Coordinator:** D'Appolonia, Italy  
**Partners:** Germany: ABGNova, Fraunhofer, STO. Greece: Kokotas Klimatismos, Proigmenes Erevnitikes & Diahistikes Efarmoges. Ireland: Delap & Waller Ecoco Limited. Netherlands: Dura Vermeer Groep, TNO. Norway: Segel, Stiftelsen Sintef. Poland: Bergamo Technologie. Romania: Institutul de Cercetari Electrohnice. Spain: Empresa Municipal de la vivienda y suelo de Madrid, Dragados, Fundacion Tecnalia Research & Innovation. Sweden: SP Sveriges Tekniska Forsknings Institut. Switzerland: Iris.

### EXPECTED IMPACT

- 3 demonstrators in total (Spain, Germany and the Netherlands)
- Estimated 30% reduction in energy use
- More than 8 dwellings involved, 3 end users and the dwellings' inhabitants engaged
- Estimated 1000 people reached by dissemination activity
- Estimated 7 year payback on investment
- €3.5 million investment from project partners
- Over 100 people trained
- 33% of project partners are SMEs
- 3 technologies may be taken to market
- At least 3 patents may be applied for

# AMBASSADOR

## Overview

The EU has set itself ambitious targets to achieve clean and secure energy for tomorrow. An optimal use of available tools is necessary to meet these targets. A wide range of technologies and methods exist to improve energy efficiency, reduce emissions and turn renewable into viable energy sources. However, the research effort has only concentrated on stand-alone buildings, dependant on their immediate environment. A new approach is needed to achieve the best possible results and highest energy savings starting at the building level and extending to a district level, taking into account district players.

During the course of AMBASSADOR a district wide holistic energy optimisation system will be introduced. This will take advantage of possible shared usage of local energy production and storage in addition to complementing energy

## Flexible buildings to make eco-friendly districts

AMBASSADOR's ultimate goal is to study, develop and experiment with systems and tools aimed at optimising energy usage in the perimeter of a district. These tools will manage energy flows; predicting and mastering energy consumption and production. The developed system will optimise the energy flows for specific objectives such as CO<sub>2</sub> reduction, net cost optimisation or energy outages mitigation.

consumption profiles. Management system functionalities will be developed to optimise building energy consumption. Selected functions or services proposed by the system will then be validated through a number of scenarios on three validation sites (France, Greece and the UK).



### KEY FACTS

**Start date:** November 2012  
**Duration:** 48 months  
**Total budget (€):** 9.8 million  
**Website:** [www.ambassador-fp7.eu](http://www.ambassador-fp7.eu)  
**Coordinator :** Schneider Electric Industries SAS, France  
**Partners:** Belgium: European Consulting Brussels. Czech Republic: AMIRES. Finland: VTT. France: CEA-INES. Germany: Leclanché. Greece: National Technical University of Athens. Italy: D'Appolonia. Netherlands: CISCO. Spain: Tekniker, Zigor R&D. Switzerland: CSEM, Neurobat, Planair. UK: ZEDfactory.

### EXPECTED IMPACT

- 3 demonstrators in total (France, Greece and UK)
- 24% reduction in energy use and 11-17% reduction in CO<sub>2</sub> emissions
- €3.4 million investment from project partners
- 33% of project partners are SMEs

# RESILIENT

## Overview

Growing investments in distributed energy resources, energy storage, plug-in electric vehicles, and active management of distribution networks will foster new technology platforms and business models to manage the increased level of diversity and complexity of dynamic multisource energy management. Today, several concepts have been developed to improve integration of renewable energy sources in the grid: Virtual Power Plant, Energy Hub and Micro grid. RESILIENT, funded within the EeB.NMP. 2012-1 theme "Interaction and integration between buildings, grids, heating and cooling networks, and energy storage and energy generation systems" fulfils the scope to manage and correlate different energy sources and storages in a dynamic way. RESILIENT advocates the development of an open energetic ecosystem, based on the innovative integrated combination of the micro grid

## Coupling renewable, storage and ICTs, for low carbon intelligent energy management at district level

The RESILIENT project aims to design, develop and install a new concept of interconnectivity between buildings, distributed energy resources and grids, assessing the associated energy and environmental benefits. The proposed integrated concept will be modelled, simulated and evaluated in three pilots: UK, Belgium and Italy. RESILIENT will facilitate the implementation of distributed and renewable energy resources at the building and district level.

and energy hub concepts applied at district level. Decision making in operation of distributed energy, resources operation, power levelling, as well as energy storage and prioritisation of different loads are among the main achievements of the RESILIENT project. Collaboration with its sister-project AMBASSADOR is already planned to broaden the scope of results.



### KEY FACTS

**Start date:** September 2012  
**Duration:** 48 months  
**Total budget (€):** 8.1 million  
**Website:** www.resilient-project.eu  
**Coordinator:** D'Appolonia S.p.A., Italy  
**Partners:** Belgium: Cordium CVBA, Infrac, Terra Energy NV, VITO. France: Centre Scientifique et Technique du Batiment, Commissariat al Energie Atomique et aux energies alternatives, Sigma Orionis. Italy: Università degli Studi di Genova, Vipiemme S.p.A. Spain: Acciona Infraestructuras S.A. UK: Cardiff University, Building Research Establishment Ltd., Blaenau Gwent County Borough Council.

### EXPECTED IMPACT

- 3 demonstrators in total (UK, Belgium and Italy)
- 20% reduction in primary energy demand and 20% reduction of CO<sub>2</sub> emission reference level
- 47 dwellings involved and over 400 end users engaged
- Over 2200 people reached by dissemination activity
- €2.6 million investment from project partners
- Over 100 people trained
- 21% of project partners are SMEs
- 5 technologies may be taken to market

# NewBEE

## Overview

The increasing cost of energy and the availability of new building technologies are expected to increase the market for low carbon solutions. Performance-based business models must be introduced in order to step up the adoption of energy efficient solutions. Collaborative networks enabling the development of business models allow early involvement of all value chain stakeholders in the retrofitting process. These business networks will provide access to competitive knowledge related to the best available technologies for retrofitting and win-win financial schemes. Innovative solutions offering new ways of working and comprising hi-tech infrastructures and services are urgently needed. These will enable stakeholders (mainly SMEs) access to both competitive knowledge and business networks.

## Novel business model generator for energy efficiency in construction and retrofitting

NewBEE proposes different business performance-based models for retrofitting projects depending on the typology of the building, the ownership scheme, the best technology to use, the funding scheme and the fiscal incentives. Based on these inputs, NewBEE will propose possible new business models to boost retrofitting projects that support energy efficiency solutions in Europe, especially by SMEs.

NewBEE will develop a system enabling SMEs to generate new performance based business models for energy efficient retrofitting and will provide to SMEs:

- Advice and support to identify or develop new business opportunities
- Easy configuration/implementation of new business models

- Develop and set-up processes supporting the new business models
- Store and reuse gathered knowledge



### KEY FACTS

**Start date:** October 2012  
**Duration:** 36 months  
**Total budget (€):** 4.5 million  
**Website:** www.newbee.eu  
**Coordinator:** FUNDACIÓN TECNALIA, Spain  
**Partners:** Finland: Eriksson, FINNERGIA, KVA, VTT. Germany: ATB, Conclude, FHG, ifA-Bau Consult, Rahm. Italy: UniPD. Malta: AcrossLimits. Slovenia: SGG, ZRMK. Spain: Acciona, ESLABAN, TEUSA.

### EXPECTED IMPACT

- 4 demonstrators in total (Spain, Slovenia, Germany and Finland)
- 15% expected reduction in energy use and 0.5Mt CO<sub>2</sub> savings
- 10,000m<sup>2</sup> renovated surface area
- 8,000 m<sup>2</sup> efficient new build area
- 4 dwellings involved and 300 end users engaged
- 50,000 people reached by dissemination activity
- 5% estimated return on investment
- 200 people trained
- 52.9% of project partners are SMEs
- 1 technology may be taken to market

# PROFICIENT

## SME network business model for collective self-organised processes in the construction and retrofit of energy efficient residential districts

PROFICIENT is an SME-targeted collaborative research project that aims to create large business opportunities for Small and Medium Enterprises (SMEs) by exploiting the newly emerging process of Collective Self-Organised (CSO) housing for constructing and retrofitting energy efficient and low carbon residential districts. PROFICIENT is establishing an 'SME network business model' of joint product-service providers of EeB solutions supported by an e-marketplace.

### Overview

PROFICIENT exploits the emerging trend and fast growing market of Collective Self-Organised (CSO) housing in the EU in order to create new business opportunities for SMEs in the energy efficient building sector. CSO housing is the process through which a group of homeowners purchase a piece of land or existing properties; procure professional companies for design, construction and maintenance; and directly manage the project from planning until delivery and use. PROFICIENT focuses on CSO housing projects for mid-size residential districts. To realise the EU goals of energy efficient and low carbon districts, PROFICIENT deals with all of the four key success factors in large-scale district construction and retrofitting:

- The best match between the homeowners' CSO processes and SMEs' business models

- The best match between the users' requirements and SMEs' technology solutions
- The best regulatory and market environment with enabling financial and ICT tool sets, especially addressing total cost of ownership and participatory design supported by semantic web e-marketplace

- The best practices sustained by Europe-wide Communities of Practice (CoP)



#### KEY FACTS

**Start date:** September 2012  
**Duration:** 48 months  
**Total budget (€):** 7.2 million  
**Website:** www.proficient-project.eu  
**Coordinator:** TNO, The Netherlands  
**Partners:** Bulgaria: RDF. Czech Republic: IRS Servis, STU-k. Germany: 3L. Hungary: Energosys, Metropolitan Research Institute. Italy: Becquerel Electric, Ipostudio The Netherlands: DEMO Consultants, Municipality of The Hague, SBR. Norway: Husbanken, SINTEF. Spain: SOLINTEL. UK: Lancaster Cohousing Ltd, Lancaster University.

#### EXPECTED IMPACT

- 4 demonstrators in total (UK, Netherlands, Hungary and Czech Republic)
- 25% reduction in energy use
- Estimated 200 dwellings involved
- 2,600 people reached by dissemination activity
- €1.8 million investment from project partners
- 300 people targeted for training
- 70% of project partners are SMEs
- 20 technologies may be taken to market

# UMBRELLA

## Business model innovation for high performance buildings supported by whole life optimisation

UMBRELLA will develop an innovative, web-based decision-support application, which will support and connect the range of stakeholders involved in energy efficiency retrofitting of the built environment. The portal will provide users with common independent evaluation tools built around new and adaptable business models linked with energy efficient design solutions. This will be based around a whole life scenario e.g. design, operation and end-of-life.

### Overview

Many barriers exist when considering the sustainability of the built environment. Optimising energy efficiency in buildings is often a management rather than a design issue. For this reason, it requires the development of decision support tools providing information about buildings' energy consumption and methods of implementation and incentive solutions benefiting all stakeholders. UMBRELLA will address this issue through the development of an innovative, web-based decision-support application. This will provide common independent evaluation tools built around new and adaptable business models. The interface will use guided navigation to ascertain information from users such as: key stakeholders; building location; building type; new or retrofit build; owner objectives and preferences e.g. energy efficiency, carbon and budget requirements etc. Business models

specific to the project and stakeholders will then be provided through the online dynamic web portal. This will allow users to explore and optimise different business models and related implications and recommendations for interventions to their specified building. This can be applied to any building at any stage of design or use.



#### KEY FACTS

**Start date:** September 2012  
**Duration:** 36 months  
**Total budget (€):** 2.9 million  
**Website:** www.umbrella-project.eu  
**Coordinator:** IES Ltd, UK  
**Partners:** France: LGI Consulting. Ireland: Trinity College Dublin, University College Cork. Italy: D'Appolonia, E++, STAM. Poland: NAPE. Spain: Solintel. UK: Exeter University.

#### EXPECTED IMPACT

- 4 demonstrators in total (UK, Spain, Poland and Italy)
- 3.096Mt per year CO<sub>2</sub> savings
- 1000 people reached by dissemination activity by the end of the project
- €1.9 million investment from project partners
- 60% of project partners are SMEs
- 2 technologies may be taken to market
- 2 patents may be applied for

## ICT platform for holistic energy efficiency simulation and lifecycle management

HESMOS aims to achieve an industry-driven holistic approach for sustainable optimisation of energy performance and CO<sub>2</sub> emissions reduction. The project addresses integrated design, facility management and sophisticated energy performance simulation. Existing fragmented building and environmental data are interlinked into a BIM-based framework enabling complex energy analyses and performance monitoring in all lifecycle phases where potential for energy savings exists.

### Overview

The project consortium anticipated that public use facilities built and operated as PPP projects provide unique opportunities for energy savings and CO<sub>2</sub> reduction due to the close, long-term client – contractor relationships. A major advantage of PPP projects is that design, construction and operation are increasingly understood as a holistic lifecycle. Energy optimisation is thereby not driven by individual phases and disciplines with often considerable negative impacts to other phases but by long reaching lifecycle decisions. However, the current highly disruptive information flows and the distributed heterogeneous information collected from multiple sources provide substantial barriers to the achievement of more efficient results. This leads the industry to request integrated concurrent engineering tools that would allow energy and cost simulation studies for decision making at any time during the whole building lifecycle.

HESMOS sets out to reduce the complexity of lifecycle simulation and the related information management in all design, operation, refurbishment and retrofitting phases by:

- Extending existing Building Information Modelling (BIM), energy simulation and cost calculation tools for a seamless lifecycle exchange of the needed information
- Integrating energy simulation tools in design and facility management so that BIM-CAD and FM tools can be used as energy simulators and gap identifiers

- Integrating sensor data from Building Automation Systems (BAS) with BIM-based energy simulation and performance management applications
- Developing web-based navigation tools for building performance visualisation by multiple actors and decision-makers in the lifecycle process
- Developing BIM-based web services for fast, informed and efficient study of design and retrofitting alternatives concerning energy performance and total costs

### Key Achievements

- Web-based Integrated Virtual Energy Lab (IVEL) enabling energy simulations, performance monitoring and informed decision making in multiple lifecycle phases, from early design to facility operation and refurbishment
- Interoperability of energy tools on the basis of a common information framework extending current standard BIM/IFC to an energy-enhanced multi-model (eeBIM)
- Integrated energy efficient design via the HESMOS IVEL and a set of knowledge-based energy templates, energy KPIs and post-processing facilities
- Energy efficient facility management via integrated use of sensor data from building automation systems and BIM-based performance management applications



### KEY FACTS

**Start date:** September 2010

**Duration:** 40 months

**Total budget (€):** 4.6 million

**Website:** www.hesmos.eu

**Coordinator:** Technische Universität Dresden - Institute of Construction Informatics, Germany

**Partners:** Finland: Granlund Oy. Germany: Chair of Technical Information Systems, Institute of Building Climatology, Obermeyer Planen + Beraten GmbH (OPB), Technische Universität Dresden – Institute of Construction Informatics. Netherlands: Royal BAM Group NV. Slovakia: NEMETSCHKEK Slovensko S.R.O.. UK: AEC3 Ltd.

### EXPECTED IMPACT

- 2 demonstrators in total (Germany)
- 65m<sup>2</sup> surface area renovated and insulated for thermal comfort optimisation
- 5 buildings involved, end users are currently the project partners BAM and OPB
- Several hundred people reached by dissemination activity
- Estimated 170% return on investment over the next 5 years
- Estimated €1.9 million investment from project partners
- Key training actions: WebCONs organised for training, end-user workshops
- 10 people trained per year
- 33% of project partners are SMEs
- 4 technologies may be taken to market

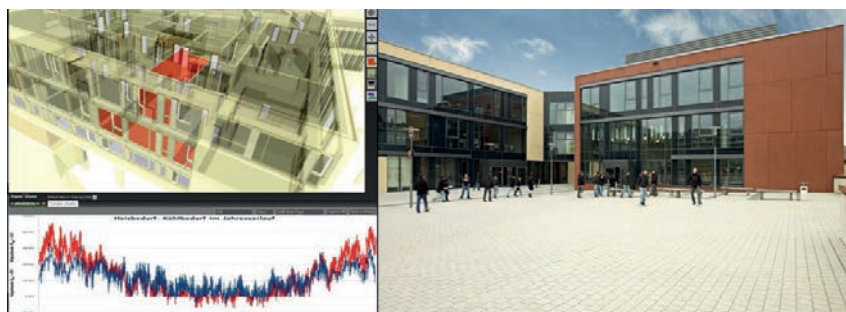

Left: BIM-based energy performance visualisation on the web with the HESMOS nD Navigator. Right: the HESMOS pilot project: Professional school Pforzheim, Germany. (photo: courtesy S. Gagnato)

# KnoholEM

## Knowledge-based energy management for public buildings through holistic information modelling and 3D visualisation

The KnoholEM project's aim is to engineer an intelligent energy management solution that will considerably reduce energy consumption, by both the systematic avoidance of energy wastage in buildings and by knowledge-based holistic optimisation of energy consumption. The solution will be applied and configured for a wide range of building types from any EU region, based on knowledge representation technologies.

### Overview

Intelligent management of energy efficiency in the building sector is a key measure for global reduction of greenhouse gas emissions. Management also facilitates user cost reductions in the context of growing energy prices and harshness of natural resources.

At present the commissioning of public buildings requires an energy efficiency certification derived from energy models generated by energy simulation tools. These tools must factor in construction, thermal properties and environmental models. The complexity of assembling and interlinking elements of these different models presents a major challenge. KnoholEM addresses this challenge by applying a holistic, knowledge based approach that maps these disparate models into a single open ontological format. In this way the relevant elements from different models which can easily be captured, filtered, searched, mapped and interlinked. Existing tools and platforms can be leveraged to use this scheme to flexibly extend, tune and manage the evolution of open model schemes.

This intelligent energy management solution, based on existing knowledge technology such as functional modelling and ontology, will be used in smart

buildings along with Building Automation Systems (BAS). It is enhanced by multi-agent systems and energy consumption behavior simulation with realistic visualisation assistance.

KnoholEM includes five demonstration buildings in Spain and the Netherlands which are used by the consortium to develop, enhance and extensively test solutions. An overall knowledge base has been created through detailed analysis of the structure of the demonstration buildings and their energy consuming/producing devices, intelligent interlinking of building usage with its energy demand, as well as by various energy consumption behaviour simulations.

### Key Achievements

Through knowledge accumulated within the extended validation phase, KnoholEM facilitates up to 30% of energy savings depending on the building. Success of the technical approach derives from the choice of semantic web ontology format standardised by the World Wide Web consortium which enables the use of a much wider range of open knowledge modelling, parsing etc. First achievements are: development of specific ontologies populated for specific buildings, definition of the communication system and protocol, and development of a number of prototypes for testing and validation.



### KEY FACTS

**Start date:** September 2011

**Duration:** 36 months

**Total budget (€):** 4.4 million

**Website:** [www.knoholem.eu](http://www.knoholem.eu)

**Coordinator:** Building Research Establishment LTD, UK

**Partners:** Germany: Karlsruher Institut fuer Technologie, Steinbeis Innovation gGmbH. Ireland: Trinity College Dublin. Italy: CETMA, Matrix Spa, Tera S.R.L.. Netherlands: Stichting Smart Homes, Woningstichting de Zaligheden, Haagse Hogeschool. Spain: BDigital, Isotrol. UK: Cardiff University.

### EXPECTED IMPACT

- 5 demonstrators in total (Spain and the Netherlands)
- Up to 30% reduction in energy use
- Up to 1000 people reached by dissemination activity
- €1.3 million investment from project partners
- 38% of project partners are SMEs
- 2 technologies may be taken to market
- 1-2 patents may be applied for



Forum building WSZ, Kerkebogten Eersel, Netherlands

# Odysseus

## Open dynamic system for saving energy in urban spaces

The aim of the Odysseus project is to develop an Open Dynamic System (ODYS) enabling the 'holistic energy management' of the dynamics of energy supply, demand and storage in urban areas, on top of an open integration platform supporting the integration scenarios for designated urban areas (exemplified in the cities of Rome and Manchester).

### Overview

The concept of holistic energy management covers the monitoring of energy operation in areas according to 1) dynamic energy profile information for relevant 'energy nodes' and 2) the actual conditions and behaviour of nodes. Based on integral monitoring of planning and actual information, problems can be highlighted (deviations) and recommendations for resolutions suggested. In general, optimisation including commercial negotiation processes between stakeholders (long term decision support) can be developed for real-time but also for more tactical or even strategic adaptations (adding/changing nodes, etc.). The integration platform will capture all energy node information in a "dynamic Energy Profile Card" structured according to a proposed full taxonomy of 'energy node' types including properties and interrelationships. The expected achievements for Odysseus include:

- Integration scenarios: business cases/models

- Open Integration Platform: open information sharing environment where data for urban areas is managed in an open uniform way
- Holistic Energy Management System: providing end users with fully interoperable software tools for holistic dynamic management (monitoring and decision making support)
- Validation of the above: operations based on the demonstration plan and implementation strategies



#### KEY FACTS

**Start date:** November 2012  
**Duration:** 36 months  
**Total budget (€):** 3.7 million  
**Website:** www.smart-eedistrict.eu  
**Coordinator:** Telvent, Spain  
**Partners:** France: CSTB. Italy: Comune di Roma, EsoCeNet. Netherlands: Priva BV, TNO. Spain: Advantic Sistemas y Servicios. UK: Manchester City Council.

#### EXPECTED IMPACT

2 demonstrators in total (Italy and UK)

- 29% reduction in energy use and 0.05Mt per year CO<sub>2</sub> savings
- 2500 people reached by dissemination activity
- 10% estimated return on investment
- €3.7 million investment from project partners
- Key training actions: Data modelling initiative\ workshop as part of the European ICT4E2B forum
- 30-50 people trained
- 2% of project partners are SMEs
- 4-6 technologies may be taken to market
- 1 patent may be applied for

# ORIGIN

## Orchestration of renewable integrated generation in neighbourhoods

The project will deploy monitoring and actuating equipment in 3 European communities to permit the development of an energy orchestration system. This will allow the shifting of energy loads to better match local renewable energy generation, thus reducing carbon emissions. Loads will either be actuated automatically or by the building occupants acting upon information provided by the ORIGIN system.

### Overview

In the European Union (EU) energy usage in buildings is responsible for approximately 40% of the total energy consumed each year by member states and 36% of total EU CO<sub>2</sub> emissions. Increasingly, many communities across the EU have installed a variety of renewable energy systems. The potential of renewable energy generation to achieve carbon emission savings is severely restricted by the fact that renewable supply is often poorly aligned with energy demand. However, at the community or neighbourhood level significant additional opportunities exist for optimising the alignment of renewables supply with community demand. Origin was conceived to address this mismatch between energy supply and energy demand by integrating consumption and generation subsystems on a community scale. Origin's primary objective is to demonstrate increased use of community generated energy

thus reducing carbon emissions. The technology will be installed in large and small groups of buildings in three communities: Damanhur (Italy), Findhorn (Scotland) and Tamera (Portugal).



#### KEY FACTS

**Start date:** November 2012  
**Duration:** 36 months  
**Total budget (€):** 4 million  
**Website:** www.origin-energy.eu  
**Coordinator:** Heriot-Watt University, UK  
**Partners:** Germany: Fraunhofer-Gesellschaft zur Foerderung der Angewandten Forschung E.V. Italy: Solera SCRL. Portugal: ILOS - Peace Research Centre LDA, ISA. Spain: Instituto Tecnológico De Informatica. UK: Findhorn Foundation College LBG, University of Strathclyde.

#### EXPECTED IMPACT

- 3 demonstrators in total (UK Portugal and Italy)
- 15% target reduction on imported energy
- 90 dwellings involved and 1000 end users engaged
- Estimated 3 million people reached by dissemination activity
- €1.3 million investment from project partners
- Key actions: On-going hardware and interface training.
- 90 people trained
- 50% of project partners are SMEs
- 2 technologies may be taken to market

# SEEMPubS

## Smart energy efficient middleware for public spaces

The SEEMPubS project aims to reduce the carbon footprint and energy usage of existing public buildings and spaces without significant construction works. This is done through intelligent ICT-based service monitoring and energy consumption management. The project will focus on historical buildings in order to avoid damage by extensive retrofitting.

### Overview

SEEMPubS provides control for appliances in order to optimise energy usage without compromising comfort or convenience and offers decision makers strategies and tools needed to plan energy saving measures. SEEMPubS makes use of service-oriented middleware (Linksmart, previously Hydra) for embedded systems and creates services and applications across heterogeneous devices to develop an energy-aware platform. The project platform provides the functionality and tools to add energy efficiency features to monitor dynamic sensor data in real time, taking advantage of natural resources and controlling the operation of both passive and active environmental systems. The objective is to ensure best possible comfort conditions with the most efficient use of energy.

SEEMPubS aims to develop an integrated electronic system to monitor different building models, technical building services, electronic devices and operations in order to optimise and integrate all maintenance functions. The implementation of an interoperable web-based software solution will monitor real-time energy performance and provide control for lighting, heating, ventilation and air conditioning services through wireless sensor networks in existing buildings and open public

spaces. The monitoring system will be validated via an iterative methodology. The project will provide multi-dimensional visualisation starting from a set of BIM parameters for building operations and data sharing from technical systems. SEEMPubS aims to raise people's awareness of energy efficiency in public spaces. Research results achieved within the project will be translated into a model for existing buildings and public spaces in Europe.

### Key Achievements

- Design of a new building management system and implementation of the Linksmart middleware to allow integration of products from different vendors based on different communication protocols and to offer services from the design of integrated systems to the optimisation of operation and maintenance phases
- Tested dynamic simulations for each case study to estimate annual energy demand for lighting and HVAC systems and potential energy savings due to more efficient control strategies
- Realisation of building information models for each building in order to test and optimise interoperability between architectural and energetic software
- Personalisation of data visualisation for different end users through a dedicated web portal, and the use of Augmented Reality associated with QR code as an interactive communication solution to develop an efficient and user-friendly facility management process based on BIM, leveraging on human awareness and competence.

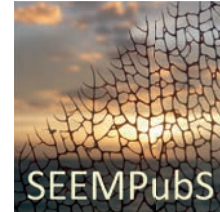

### KEY FACTS

**Start date:** September 2010

**Duration:** 36 months

**Total budget (€):** 2.9 million

**Website:** [www.seempubs.polito.it](http://www.seempubs.polito.it)

**Coordinator:** Politecnico di Torino, Italy

**Partners:** Belgium: Katholieke Universiteit Leuven. France: Sinovia SA, Université Claude Bernard Lyon 1. Germany: Fraunhofer-FIT. Italy: Centro Ricerche Fiat, Istituto Superiore Mario Boella, STMicroelectronics. Sweden: CNet Svenska AB.

### EXPECTED IMPACT

- Key training actions: Implementation of an ICT system for energy measurement and accounting to manage energy intensity downwards and productivity upwards. Establishment of a collaboration framework between the ICT and buildings and construction sectors aimed at exploiting opportunities for the development of ICT-based systems in compliance with the Energy Performance of Buildings Directive.

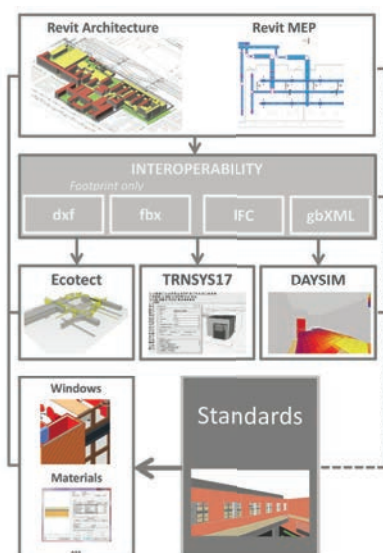

Complexity and heterogeneity of architectural technologies and solutions

## Self-powered wireless sensor network for HVAC system energy improvement

The project aims to reduce energy consumption through HVAC system performance enhancement. This is achieved due to an ICT based building integral wireless connectivity system that can support the building condition monitoring, and real time control and actuating scheme. The objectives include; empowerment of building monitoring through an extremely cost effective SP-MM-WSN and development of thermal simulations for heating systems which are compared with data from sensors.

### Overview

The project focuses on space heating and cooling aspects, proposing a solution beyond existing wireless based HVAC control systems. The solution is derived from the use of a Self-Powered Multi Magnitude Wireless Sensor Network (SP-MM-WSN) for building thermal condition monitoring. The network avoids cables and removable batteries, due to a combination of extremely energy efficient wireless communication technology, ultra-low power electronics and power harvesting. The use of a SP-MM-WSN results in an easy to deploy and maintenance free building monitoring system, making it the ideal candidate for either new or existing HVAC installations.

TIBUCON provides various deliverables aligned with different technical areas of the project: ICT, construction, and building automation. There is a key deliverable which deals with the main principles for including TIBUCON-like solutions in the design flow of new buildings, and for retrofitting existing ones. There are also a set of deliverables related to the sensor unit itself, including the hardware design, communication

protocols and high level data model descriptions. In addition, gateway units will be provided for connecting TIBUCON nodes to the main building management systems in buildings. Some work in line with the definition of novel HVAC control approaches which make the most of TIBUCON's distributed monitoring will be published. Finally, after deploying the system, and running it for a year, the performance measurements along with the initial business model and exploitation plans will be delivered.

### Key Achievements

The TIBUCON system was installed in an office building and successfully used to reduce consumption while keeping comfort levels through efficient control of heating during winter and VAC during late spring and summer. The system was also installed in three apartment buildings for the evaluation/validation of the current heating control system. Both deployments suffered from problems relating to the use of power harvesting technologies and user behaviour. This encouraged the study of user interaction and its inclusion in the system design.



#### KEY FACTS

**Start date:** September 2010  
**Duration:** 36 months  
**Total budget (€):** 2.4 million  
**Website:** www.tibucion.eu  
**Coordinator:** Mostostal Warszawa S.A., Poland  
**Partners:** Belgium: Katholieke Hogeschool Kempen. Poland: E&L Architects. Spain: Giroa-Dalkia, Tekniker-IK4. UK: University of Southampton.

#### EXPECTED IMPACT

- 2 demonstrators in total (Poland and Spain)
- 9,690m<sup>2</sup> surface area renovated
- 60 dwellings involved and 60 end users engaged
- 2,226 people reached by dissemination activity (visitors to website)
- 8 people trained

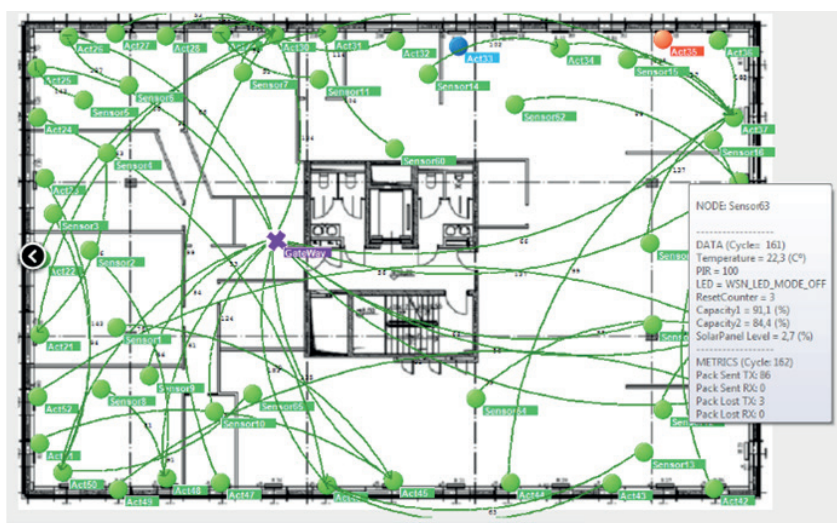

Communication between sensors and bridges

# CASCADE

## ICT for energy efficient airports

Airports consume as much energy as small cities. The CASCADE project will help to reduce energy needs by developing an ISO 50001 Energy Management Action System, supported by advanced Fault Detection and Diagnosis (FDD). The CASCADE solution will be developed, implemented and tested by a multidisciplinary team in collaboration with two major European airport hubs: Rome Fiumicino and Milan Malpensa.

### Overview

Airports are responsible for a considerable amount of energy consumption and CO<sub>2</sub> emissions; the typical electricity consumption of a major airport lies between 100 -300 GWh/year which amounts to the consumption of 30,000 to 100,000 households. Airport managers have to cope with complex buildings and advanced ICT and energy systems and are under pressure to save energy and reduce their emissions. New ICT solutions capable of integrating with various existing systems are needed to improve the energy monitoring of airport buildings. A significant part of the energy consumption at airports is due to energy systems like chillers, air handling units and lighting. These systems often operate poorly due to lack of control or insufficient design, increasing the energy consumption. Currently, building automation and management systems are not designed to perform detailed energy monitoring by detecting faults at an early stage that lead to energy losses. An upgrade of these systems is only possible with high financial investment.

The CASCADE project develops a new ISO 50001 Energy Management System (EMS) supported by Fault Detection and Diagnostics (FDD) that can integrate with existing systems to reduce the energy consumption and CO<sub>2</sub> emissions of

energy systems at airports. Hardware and software solutions are being developed to allow cost effective data acquisition, to embed FDD in an ISO 50001 context and to harmonise and administrate information from different sources over an ontological layer. The main objectives are to engage the airports in an ISO 50001 based approach in order to reach 20% energy savings on targeted systems and a three year return on investment.

### Key Achievements

Stage one delivered a review of European airport energy strategies and interest. Stage two defined the methodology for an integrated service oriented architecture that fits the technological development with requirements from the airports. Stage 3 designed a specific measurement framework for both airport pilot studies. The challenge was to develop a technical solution that can be integrated in the ICT infrastructure of airports. First airport ontology models were initiated aiming to harmonise and provide detailed information on the targeted systems for the airport operators. Tenders for additional measurement equipment were organised to enable the demonstration phase. The FDD software has been further developed and linked to the ISO 50001 EMS.



### KEY FACTS

**Start date:** October 2011  
**Duration:** 36 months  
**Total budget (€):** 3.9 million  
**Website:** [www.cascade-eu.org](http://www.cascade-eu.org)  
**Coordinator:** Fraunhofer ISE, Germany  
**Partners:** Germany: PSE AG. Ireland: Enerit Limited, Galway, National University of Ireland. Italy: Aeroporti di Roma Spa, D'Appolonia S.p.A, SEA, Sensus Mi Italia S.r.L. Serbia: Institut Mihajlo Pupin.

### EXPECTED IMPACT

- 2 demonstrators in total (Italy)
- 20% reduction in energy use and 3000t CO<sub>2</sub> savings
- 2 airport sites involved
- Estimated 1000 people reached through conferences, and 400,000 people reached through press articles
- Estimated 3 year payback on investment
- €0.4 million investment from project partners
- 33% of project partners are SMEs
- 4 technologies may be taken to market
- 4 patents may be applied for



Chilled water distribution pipes at Fiumicino airport

# SEAM4US

## Sustainable energy management for underground stations

The SEAM4US project aims to reduce energy consumption required for operating subsystems of underground public spaces, such as metro stations. This is achieved through the application of advanced modelling and intelligent technologies which through pervasive sensor networks are able to create rich representations of the environment and usage profiles. This ensures optimal and adaptive policies for controlling subsystems can be implemented.

### Overview

Underground transportation systems are big energy consumers (63.1 million kWh/year), and have significant impact on energy consumption at a regional scale. Approximately one third of networks' energy requirement is used for operating metro station subsystems and surroundings, including ventilation, vertical transportation and lighting. Although a relatively small percentage of energy can be saved with an optimal management of the aforementioned subsystems, a large energy saving in absolute terms can be obtained. In fact, every 5% of energy saved by SEAM4US in the Barcelona network in one year is approximately equivalent to the quantity of electricity consumed by 700 households.

The project's main objective is the optimisation of the energy management of underground spaces and, in particular, of metro stations through optimal control. This is achieved by exploiting synergies with the external environmental climate and with end users. SEAM4US technology is based on the ability to predict near-future states of the underground environment. This allows the implementation of proactive control policies for energy saving. SEAM4US technological framework enhances and integrates existing systems with energy metering and sensor-actuator networks by means of a middleware software layer. The gathered data is used to update a set of energy consumption

and behavioural models, which in turn support the optimal energy control of the metro station. The project's main outcomes will be the creation of technologies for optimised and integrated energy management of metro stations, the implementation of a pilot study at Passeig De Gracia subway station in Barcelona and the development of a decision support system for related mid-term investment planning.

### Key Achievements

- A comprehensive energy audit of the metro station identified the main energy consuming system
- Design and deployment of a complex energy and environmental monitoring sensor network currently gathering environmental, usage and performance data
- Integration of existing facilities and subsystems through Link Smart middleware and deployment of control actuators
- Design of an advanced modelling framework for the development of embeddable energy models for a complex environment and system in addition to the development of environmental, usage and system models of the station. The monitored energy and environmental parameters are now used for model calibration
- Design of a business model and an investment decision support tool, based on a performance scenario generator



### KEY FACTS

**Start date:** October 2011  
**Duration:** 36 months  
**Total budget (€):** 4.1 million  
**Website:** www.seam4us.eu  
**Coordinator:** Cofely Italia S.p.A., Italy  
**Partners:** Finland: Teknologian Tutkimuskeskus, VTT. Germany: Fraunhofer-Gesellschaft FIT, University of Kassel. Italy: Università Politecnica delle Marche. Netherlands: Almende. Spain: Ferrocarril Metropolita de Barcelona, Universitat Politècnica de Catalunya. Sweden: CNet Svenska AB.

### EXPECTED IMPACT

- 1 demonstrator (Spain)
- 13.7% reduction in energy use and 41.9t CO<sub>2</sub> savings per year
- Tens of thousands of end users engaged
- Thousands of people reached by dissemination activity
- Estimated 14.4% return on investment
- €1.2 million investment from project partners
- 22% of project partners are SMEs
- 10 technologies may be taken to market



The SEAM4US approach: from the data acquisition using the monitoring network to the implementation of the optimal policies through the models and the controllers

# BEAMS

## An integrated approach to manage energy efficiency in large infrastructures

BEAMS develops an advanced integrated management system which enables energy efficiency in buildings and special infrastructures from a holistic perspective. The project considers interior spaces, public spaces and the interaction of the overall compound with the grid.

The main demonstrator is hosted by FC Barcelona, at the stadium and service area, including the basketball pavilion, museum, parking spaces and training facilities.

### Overview

Europe shares common goals towards sustainability, aiming to increase energy efficiency by 20% compared to figures from 1990. ICT could be the enabling technology which helps the EU realise these goals. We have seen in recent years a dramatic change in the energy sector which will have an eminent effect on businesses and economy. The energy technologies currently in use were designed for a different era based around centralised energy generation and economies of scale. These technologies cannot fully serve the transitional period we are in.

By means of a decentralised architecture, BEAMS enables new mechanisms to extend current building management systems and achieve higher degrees of efficiency. BEAMS' strategic goal is to define and develop an advanced, integrated management system for buildings and special infrastructures for public use. The system relies on an open interoperability gateway that allows the control of already identified heterogeneous subsystems acting as sources and loads in such facilities. Nowadays they are typically found in public spaces, such as public lighting or ventilation and air conditioning systems. Others such as renewable sources or electric vehicles will become widely adopted in future years.

The proposed solution supports the building's or facility's human operator to achieve higher efficiency in the use of energy. It also opens new opportunities to third parties such as Energy Service Companies (ESCO), utilities and grid operators needing and willing to interact with BEAMS management system. They can interact through the interoperability gateway in order to improve the quality and efficiency of the service both inside and outside the perimeter of the facility.

### Key Achievements

BEAMS has completed the first version of its main prototypes: new models to integrate photovoltaic panels and electrical vehicles as mechanisms to "green" energy consumption; an open interoperable gateway capable of interfacing different systems from different vendors and scheduling loads efficiently; and finally a facility management environment that can detect anomalous situations and autonomously propose adequate mitigation actions. For normal operation, this leads to cost and energy savings, while for high demand situations this helps identify in advance the needs and how to address them.



### KEY FACTS

**Start date:** October 2011  
**Duration:** 30 months  
**Total budget (€):** 2.7 million  
**Website:** [www.ict-beams.eu](http://www.ict-beams.eu)  
**Coordinator:** ETRA I+D, Spain  
**Partners:** Germany: Fraunhofer Iwes Advancing Energy Systems. Greece: Institute of Comms&Computer Systems National Technical University of Athens. Italy: Thales Italia Spa, Università del Salento. Spain: Barcelona Digital, Sodexo Facility Management.

### EXPECTED IMPACT

- 2 demonstrators in total (Spain and Italy)
- Estimated 20% reduction in energy use
- Estimated 5,000m<sup>2</sup> build efficient area
- 2 facility operators, over 100 workers and up to 1.6 million visitors/year
- Over 1,500 people reached by dissemination activity
- 15% estimated return on investment
- €0.9 million investment from project partners
- 4 technologies may be taken to market
- 1 patent may be applied for



BEAMS high-level architecture

# SEEDS

## Self learning energy efficient buildings and open spaces

SEEDS develops innovative technologies for optimising building performance in terms of energy, comfort, and life cycle costs. It uses an innovative modelling methodology based on measurements, self-learning, optimisation techniques and wireless technologies. SEEDS can be applied to buildings and surrounding open spaces. SEEDS is particularly attractive for the retrofitting of existing buildings.

### Overview

There is a gap between the design and construction and the operation and management stages of a building. Often the design is more focused on architectural issues. At the operation and management stages, facility management is the core business. At this stage little information from BIM is available for facility management especially for existing buildings. SEEDS focuses on the operation stage of the building. It develops a Building Energy Management System (BEMS) to optimise the energy behaviour of the building over a time period. It performs detailed modelling of the HVAC and lighting equipment, energy sources and energy storages. The modelling of the energy equipment in the building is based on IFC – an open BIM data exchange format.

SEEDS implements an innovative model predictive control strategy based on sensor measurements and self-learning techniques. This methodology takes into account the properties of a building and its energy behaviour without the need of having an explicit architecture model of the building. If available, SEEDS uses BIM data of the building floorplan/layout and the building services structure. In other words, SEEDS designs a BEMS using only the information available on the building facilities and the appropriate set of measurements that are captured by wireless sensor nodes which are also required to implement the most

energy efficient control strategy. There is no need to have detailed architecture information (such as material parameters, thermal capacities etc.) and thus, SEEDS can be easily applied to the energy-aware upgrading/optimisation of existing building services systems and to the retrofitting of old buildings which may lack constructional specification details necessary for traditional systems. Moreover, the use of wireless technologies allows easy and fast deployment.

### Key Achievements

- Development of SEEDS architecture based on five components (building facility model, optimising, self-learning, Wireless Intelligent Sensors and Actuators Network (WISAN) and archive) in 3 layers (controller, data management and process interface)
- Development of the methodology for the building facility modelling, library concept for executable building facility models, database and software architecture for the modelling, configuration and execution of the SEEDS BEMS, control strategy, self-learning and optimisation techniques suitable for building energy systems, WISAN suitable for Building Automatic Systems and validation methodology for proving the concept
- Design of the Graphic User Interface
- Implementation and test of the SEEDS components and running integration tests for the SEEDS architecture



### KEY FACTS

**Start date:** September 2011  
**Duration:** 36 months  
**Total budget (€):** 4 million  
**Website:** www.seeds-fp7.eu  
**Coordinator:** CEMOSA, Spain  
**Partners:** Germany: FASA AG, Fraunhofer IIS/EAS, NSC GmbH. Norway: University of Stavanger. Spain: Ferrovial Agroman S.A, Fundación Cidaut, Software for Critical Systems. UK: University of Salford.

### EXPECTED IMPACT

- 2 demonstrators in total (Norway and Spain)
- 5-10% reduction in energy use
- 4,000m<sup>2</sup> surface area renovated
- 2 buildings involved and 760 end users engaged
- 1000 people reached by dissemination activity
- €1.2 million investment from project partners
- 2 people trained (one per building)
- 44% of project partners are SMEs
- 2 technologies may be taken to market
- 1-2 patents may be applied for

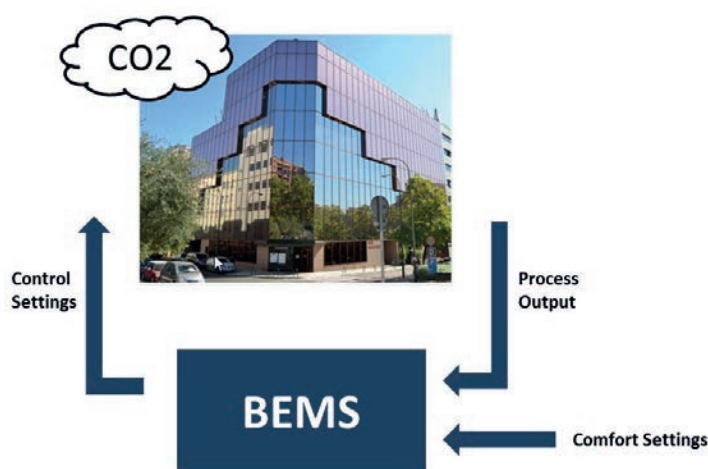

SEEDS develops an optimised BEMS and one of its demonstration buildings located in Madrid

# EPIC-HUB

## Overview

EPIC-HUB focuses on efficient management, control and decision-support energy policies at neighbourhood level. It defines an interoperable middleware solution and a structured vision for the communities to use and share renewable energy sources, energy storage, and micro-generation, to consistently realise energy savings, reduce CO<sub>2</sub> emissions and optimise energy usage.

From an energy point of view, the EPIC-HUB methodology models the neighbourhood as an energy hub or an aggregation of different energy hubs with their energy sources, storage devices and controllable loads. Furthermore, the interoperable approach of EPIC-HUB middleware will allow it to take into account all deployed ICT systems and provide meaningful information and operational constraints to the energy-hub model.

## Energy positive neighbourhood infrastructure middleware based on energy-hub concept

The goal of EPIC-HUB is to develop a new methodology, an extended architecture and services able to provide neighbourhoods with an improved energy performance. By combining powerful energy-hub based optimisation capabilities with seamless integration of pre-existing and new ICT systems, EPIC-HUB will contribute to achieve the global objective of the energy-positive neighbourhood.

To validate the adaptability of the EPIC-HUB approach, different pilot studies and communities will be involved. Challenging case studies such as Genoa Port, Belgrade Airport and Bilbao Exhibition/Fair Centre together with their surrounding neighbourhoods will provide the involvement of critical infrastructure where an innovative approach to energy management can have great impact and relevant results.



### KEY FACTS

**Start date:** October 2012

**Duration:** 42 months

**Total budget (€):** 6.7 million

**Website:** [www.epichub.eu](http://www.epichub.eu)

**Coordinator:** D'Appolonia SpA, Italy

**Partners:** Czech Republic: Honeywell, Spol. S.r.o.  
Israel: Panoramic Power Ltd. Italy: Energrid SpA,  
Terminal San Giorgio Srl, Thales Italia SpA. Serbia:  
Institu Mihajlo Pupin. Spain: Acciona Infraestructuras  
S.A., Bilbao Exhibition Centre SA, Fundacion Tekniker.  
Switzerland: Eidgenoessische Technische Hochschule  
(ETH) Zurich.

### EXPECTED IMPACT

- 3 demonstrators in total (Italy, Serbia and Spain)
- 20% reduction in energy use and CO<sub>2</sub> savings
- 100,000m<sup>2</sup> renovated surface area
- Estimated 10,000 end users engaged
- 300 people reached by dissemination activity
- 7% estimated return on investment
- €2.5 million investment from project partners
- 9% of project partners are SMEs
- 3 technologies may be taken to market
- 3 patents may be applied for

## Energy efficiency and risk management in public buildings

Deregulation of energy sectors provides challenges and opportunities alike for operators of public buildings. Exposure to energy prices and CO<sub>2</sub> emission restrictions create incentives to adopt more energy efficient technologies. Yet market and technological uncertainty necessitate decision support for risk management. EnRiMa facilitates this transition to more energy efficient public buildings by developing an optimisation based Decision Support System (DSS).

### Overview

EnRiMa develops a DSS enabling operators to manage energy flow in public buildings. This will deliver a holistic solution for meeting their energy needs in a more efficient, less costly, and less CO<sub>2</sub> intensive manner subject to comfort tolerances and long-term risk preferences. Such decision support is crucial as the EU faces the challenge of improving energy sustainability, reducing CO<sub>2</sub> emissions, and increasing the share of renewable energy technologies. A DSS for managing conflicting goals such as cost minimisation and energy efficiency improvement while accounting for risk would be an enhancement to the status quo.

Two optimisation modules have been designed: one for short-term operational decisions and another for long-term strategic decisions. The former finds hourly temperature set points for installed equipment over a typical day given details on external temperatures, building physics, and equipment thermodynamics. This operational optimisation has been implemented using data from two buildings and indicates that energy savings of at least 10% are possible by smarter operation of equipment. By contrast, the strategic model considers on-site technology investment and building retrofits over several years. Consequently, it abstracts from equipment level details but

incorporates uncertainty in energy prices, technology performance, and policy measures to provide optimal investment strategies. By varying the user's risk preferences, EnRiMa sketches out an efficient frontier comprising alternative hedging strategies. Both optimisation modules are being integrated with building energy management systems via a graphical user interface to create a prototype for commercial DSS software. As the DSS may be run under various settings, it can also inform policymakers about effects of measures on energy usage and building operators' decisions.

### Key Achievements

The project first completed the requirement assessment, energy-flow models, scenario generation, and symbolic model specification. Subsequent work has integrated the operational model for optimising energy flow with the test sites' Building Energy Management Systems (BEMS). Coupled with a graphical user interface, the prototype reads data from test sites, runs the optimisation on a remote server, and displays the results to the manager in a matter of minutes for adaptive decision support. Validation of the model's performance has been conducted using both a laboratory facility and data from the actual buildings. DSS information sessions at the test sites are scheduled for late 2013 and early 2014 in order to attract input from potential users.



### KEY FACTS

**Start date:** October 2010  
**Duration:** 42 months  
**Total budget (€):** 3.49 million  
**Website:** www.enrima-project.eu  
**Coordinator:** Stockholm University, Sweden  
**Partners:** Austria: Center for Energy and Innovative Technologies, International Institute for Applied Systems Analysis. Belgium: Minerva Consulting and Communication. Norway: Stiftelsen SINTEF. Spain: Fundación Tecnalia Research and Innovation, Hidrocarbónico Energía S.A., Universidad Rey Juan Carlos. UK: University College London.

### EXPECTED IMPACT

- 2 demonstrators in total (Austria and Spain)
- 15% reduction in energy use and 29t CO<sub>2</sub> savings per year
- 2 dwellings involved
- Estimated 1000 people reached by dissemination activity
- 10% estimated return on investment
- 22% of project partners are SMEs
- 2 technologies may be taken to market
- 2 patents may be applied for

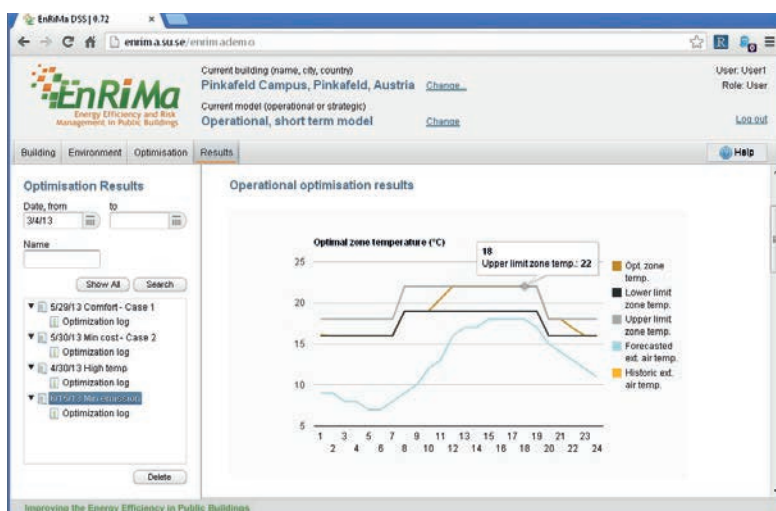

Graphical user interface for operational optimisation of the DSS

# H2SusBuild

## Development of a clean and energy self-sustaining building

H2SusBuild aims to develop a self-sustainable and zero-carbon emission hybrid energy system, in which stored hydrogen can be converted into energy in case of an energy shortage from renewable energy sources thus compensating their intermittent nature. Installation occurred in a real building in order to demonstrate that application of such a system in buildings is possible both from the perspective of technical feasibility and safety.

### Overview

The building sector is among one of the most energy consuming in Europe, accounting for nearly 40% of Europe's final energy consumption. As a major proportion of this energy comes from fossil resources, increasing energy efficiency and reducing greenhouse gas emissions of buildings (including increasing the use of Renewable Energy Sources (RES)) is a priority. However, a proper way to balance the intermittent nature of RES must be researched and consolidated to ensure the continuous operation of these energy systems.

In line with these objectives, the concept behind the H2SusBuild project was to develop a self-sustainable and zero-carbon emission hybrid energy system, in which hydrogen, stored as a pressurised gas provides an energy supply in case of an RES shortage, thus compensating for their intermittent nature. RES technologies such as photovoltaic solar panels as well as wind power generators were coupled with water electrolysis for the production of hydrogen. The produced hydrogen can be consumed on-demand in order to produce thermal and electrical energy. More specifically, RES technologies are used to harvest primary energy that can be directly applied to cover the building's contingent loads. In the case of excess renewable energy availability, the excess energy is converted to hydrogen to be used as an energy storage medium. In

case of a renewable energy shortage, the stored hydrogen is applied as green fuel in order to cover the building's electrical and thermal energy demand, through combined heat and power generation by means of fuel cells as well as by direct combustion for additional heat production when needed.

### Key Achievements

Installation and safe operation of the envisaged hybrid energy system in a real building was demonstrated by means of a full-scale installation in a building located in Lavrion (Greece). Besides improvement of single technologies, the use of an energy management and control system ensured coordination and interaction of the system components between themselves, the RES and electricity grid. This system built on optimised operational strategies, managed energy flows, and minimised the use of electricity from the grid. A safety system was also installed to guarantee safety.



### KEY FACTS

**Start date:** October 2008  
**Duration:** 48 months  
**Total budget (€):** 6.6 million  
**Website:** [www.h2susbuild.ntua.gr](http://www.h2susbuild.ntua.gr)  
**Coordinator:** D'Appolonia S.p.A., Italy  
**Partners:** Germany: Circomp, Institut für Verbundwerkstoffe. Greece: Centre for Renewable Energy Sources, National Technical University of Athens, Schneider Electric. Italy: CAVE, ICI Caldaie, Idrogen2, S.C.A.M.E. Sistemi. Norway: Det Norske Veritas. Poland: Decsoft. Spain: Acciona Infraestructuras, Ikerlan. Sweden: Catator, SKANSKA. The Netherlands: Van Berkel & Bos U.N. Studio. UK: The University Court of the University of St Andrews.

### EXPECTED IMPACT

- 1 demonstrator (Greece)
- The hybrid energy system by itself is free from CO<sub>2</sub> emissions
- 600m<sup>2</sup> surface area renovated
- Project has been disseminated at 48 events
- €3.2 million investment from project partners
- Key training actions: Training of local operators of the H2SusBuild hybrid energy system
- 5 people trained
- 39% of project partners are SMEs
- 11 technologies may be taken to market



View of the Lavrion demonstration installation

# MESSIB

## Multi-energy storage system integrated in buildings

Buildings are living labs where energy is produced, transmitted and used, becoming a crucial node for concepts like distributed generation, smart grids and energy efficiency. MESSIB provides an integrated system, based on hybrid thermo-electric concepts and novel technologies for matching production with consumption, exploiting the potential of renewables and reducing fossil fuels.

### Overview

European politics and international trends have stressed the necessity of shifting from energy models based on centralised power plants to distributed production; from dissipation to conservation of energy, from fossil fuels to renewables and from production side to demand side management. Energy storage systems allow the matching of production with loads in terms of time, power or energy. This introduces a new methodology in the design of HVAC systems based on annual energy balance through the building, calculated on base loads instead of peaks of power, integrating multiple generation systems with advanced strategies for maintaining the comfort of the indoor environment. Existing technologies are characterised by high prices, low energy density and complicated utilisation coming from the industrial sector and are often too complicated to be integrated and operated.

The MESSIB project's purpose was to adapt such technologies to edification, in terms of efficiency and implementation in order to reduce the load of the building, increasing the penetration of renewables and enhancing the energy efficiency of the entire installation. An integrated concept, developed by combining four different types of storage for heat and electricity, based on new materials, new technologies, new computational tools and new methodologies was achieved

by joining the multiple skills of different European partners. The purpose was to acquire experience and achieve new products at pre-industrialisation level.

The expectation was a scalable modular system to be integrated in new and existing constructions, reducing the load profile and use of primary energy from fossil fuels and so leading to the concept of building self-sustainability and integration with smart cities.

### Key Achievements

- Phase Change Materials (PCMs) – micro encapsulation of salt hydrates and paraffin; computational tools for energetic behaviour
- Borehole – grouting material for increased ground conductivity and heat exchanger with reduced thermal resistivity
- Flywheel – 50,000 rpm flywheel, with magnetic bearing, vacuum carcase and orthotropic rotor
- Vanadium redox Flow Battery – new stack material combined with a new design for enhanced efficiency
- Integrated control system – predictive algorithms based on weather forecast and simulation with dynamic software
- Computational tool – for PCM behaviour, borehole productivity, flywheel energy balance and battery control



### KEY FACTS

**Start date:** March 2009  
**Duration:** 48 months  
**Total budget (€):** 8.5 million  
**Website:** www.messib.eu  
**Coordinator:** Acciona, Spain  
**Partners:** Finland: Uponor, VTT. France: CSTB. Germany: BASF, Fraunhofer, KnauflKG, Ustutt. Greece: Knauf Abee, NTUA.HMCS. Italy: CNR-ISAC, D'Appolonia, Gesta. Poland: Mostostal. Netherlands: ECN, Wansdronek. Slovenia: CCS, Robotina. Spain: Aidico, Tecnalia, Tekniker, Zigor.

### EXPECTED IMPACT

- 4 demonstrators in total (Germany, Greece and Spain)
- 15% reduction in energy use
- 151m<sup>2</sup> surface area renovated, 15m<sup>2</sup> new build efficient area
- 2-5 dwellings involved
- 10,000 people reached by dissemination activity
- Key training actions: Web videos, conferences, fairs and workshops
- Over 300 people trained
- 7% of project partners are SMEs
- 3 technologies may be taken to market
- 3 patents may be applied for

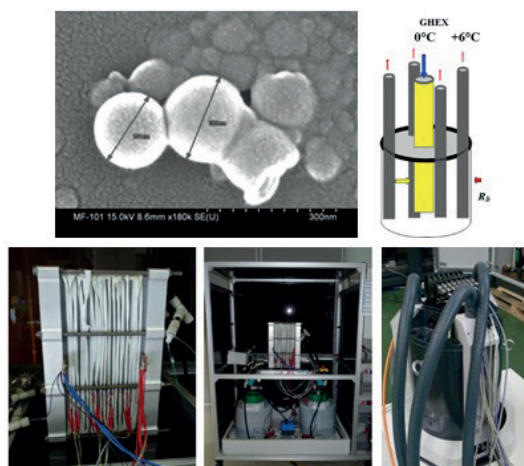

Clockwise from top left: microencapsulated PCM, ground heat exchanger, VRB stack, flywheel

# SportE2

## Intelligent management system to integrate and control energy generation, consumption, and exchange for European sport and recreation buildings

SportE2 “Energy Efficiency for European Sport Facilities” is challenging the world of sport facilities to improve their energy efficiency. Through the development of smart metering, integrated control systems, intelligent optimisation strategies and multi-facility benchmarking dedicated to sport facilities, this project aims to deliver 30% energy savings and carbon emission reductions with a return of investment of 5 years.

### Overview

The European sport and recreation building stock accounts for about 1.5 million buildings in Europe. They represent a significant portion of the overall building stock and consume a disproportionate amount of energy (6-8%). Sports facilities are unique for the following reasons:

- Energy demand profiles (timing and peaks)
- Usage patterns (long periods of low use and then short periods of high use during a sporting event)
- Comfort and ventilation requirements
- Facility characteristics (e.g. swimming pools, indoor courts, saunas, etc)
- How they are owned and managed
- How they can encompass large open spaces (multiple buildings, complexes, parking areas, lighting, etc.)

With this background, the aim of SPORTE2 is to develop an integrated, modular, and scalable ICT system to manage energy consumption, generation, and exchange locally and within the larger context of the smart grid/neighbourhood. Considering the particular type of facilities (large court areas, swimming pools etc), the maintenance of comfort conditions will be one of the main objectives together with energy consumption.

### Key Achievements

SportE2 is client and pilot study focused. After initiation the project immediately became involved with energy audits and a study of energy consumption patterns at each of the three project pilot sites: Fidia Sport (Italy), Sport Complex Santa Maria De Lamas (Portugal), and the Extebarri Municipal Sport Centre (Spain). Module prototypes and first optimisation scenarios have been tested at Tecnalia’s KUBIK. SportE2’s installation plans for pilot studies have been developed and are ready to be implemented.



### KEY FACTS

**Start date:** September 2010

**Duration:** 42 months

**Total budget (€):** 4.7 million

**Website:** [www.sporte2.eu](http://www.sporte2.eu)

**Coordinator:** D'Appolonia SpA, Italy

**Partners:** Italy: Fidia Sport, Schneider Electric, STARING, Università Politecnica della Marche. Portugal: Intelligent Sensing Anywhere ISA, Self Energy. Spain: EmteSport, Tecnalia. UK: Cardiff University.

### EXPECTED IMPACT

- 4 demonstrators in total (Italy, Portugal and Spain)
- 10% reduction in energy use
- 3,000 end users engaged
- 3,000 people reached by dissemination activity
- 5 years estimated payback on investment
- €1.7 million investment from project partners
- 40% of project partners are SMEs
- 4 technologies may be taken to market
- 1 patent may be applied for



Fidia Rome Swimming Pool and SPORTE2 HOW software interface

## Sounds for energy control of buildings

S4ECoB aims to build an innovative ICT solution for EeB that will be convenient and easy to implement. The project intends to use and integrate available technologies along with a network of low-cost microphones to accurately monitor the occupancy level, synchronising such information with the Heating, Ventilation, Air Conditioning and Lighting (HVACL) systems to reduce the consumption of energy without reducing comfort.

### Overview

S4ECoB will develop and deliver a prototype to optimise the existent Building Energy Management Systems (BEMs) by means of acquiring, identifying and adding the parameters of occupancy level in buildings and surroundings to enhance operations and eliminate unnecessary energy consumption of HVACL systems, maintaining user comfort. This will be achieved through the integration of a low-cost novel network of audio sensors with other building sensing and controls and the improvement of the strategies and algorithms of automation and conditioning. These will be deployed, calibrated and validated in two shopping malls and one international airport in real operational situations.

This Building Energy Management System Optimiser (BEMO) is mainly composed of three parts: the audio and sensor system for listening and sensing, the acoustic processing system for detecting and learning acoustic events in order to distinguish levels of occupancy and types of activity, and the management system for monitoring and optimising the strategies and algorithms for control of the building automation system.

The objective of the S4ECoB is to deliver the following prototypes and artefacts:

- Embedded Acoustic Processing Unit (APU): low-cost, adaptable and scalable embedded audio processing HW/SW platform

- Occupancy sensor: easy to install device which monitors the occupancy level and transfers the data in near real-time to the BEMO
- Acoustic water flow metering: scalable air/water flow metering system for HVAC systems transferring sensor data wirelessly to central control and optimisation units
- A central Acoustic Processing Server (APS) processing unknown sounds and managing retraining capabilities
- BEMO: management central unit connecting BEM system with the occupancy data
- Manual for use, installation, integration and set-up of the BEMO system

### Key Achievements

During this first stage all work has focused on achievement of three milestones:

- Audio sensor network prototype. Design of the audio front-end hardware and integration of occupancy sensor network with BEMO server
- Identification and collection of system requirements and specifications. Collection of the technical requirements and specification useful for defining each single module of the whole project system
- Definition of the control strategies for the energy management system and validation methodologies for the acoustic system



### KEY FACTS

**Start date:** October 2011

**Duration:** 42 months

**Total budget (€):** 3.9 million

**Website:** www.s4ecob.eu

**Coordinator:** Solintel M&P SL, Spain

**Partners:** Austria: Austrian Institute of Technology. Germany: Fraunhofer Institute for Digital Media Technology, Institute for Microelectronic & Mechatronic Systems. Italy: D'appolonia SpA, Società per Azioni Esercizi Aeroportuali. Netherlands: Corio NV.

### EXPECTED IMPACT

- 3 demonstrators in total (Spain and Italy).
- 15% reduction in energy use and 57% reduction in CO<sub>2</sub> emissions per year
- More than 1,100 people reached by dissemination activity
- €1.3 million investment from project partners
- 1 technology may be taken to market

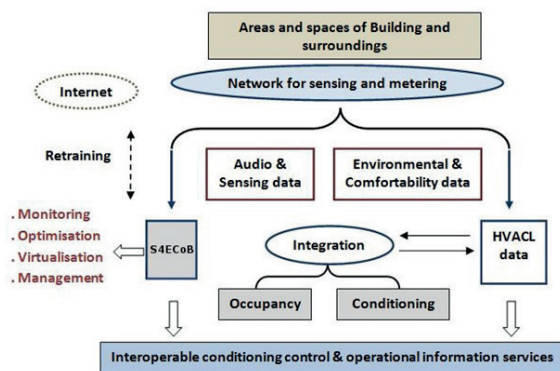

Architecture and data flow of Building Energy Management Optimiser (BEMO)

# COOPERaTE

## Overview

Buildings are responsible for 40% of energy consumption and 36% of EU CO<sub>2</sub> emissions. Improving the energy consumption and holistic performance of buildings and neighbourhood systems is a cost-effective way of tackling climate change and improving energy security. While energy efficiency in buildings has been the focus of a range of research programmes and a strategic target for many organisations, energy management at the neighbourhood level remains a new topic. In order to adapt the concept of building management systems to this scenario, COOPERaTE aims to develop an open, scalable service and management platform that integrates local monitoring and control functions for energy management.

The neighbourhood integration and service platform will provide industry

## Control and optimisation for energy positive neighbourhoods

COOPERaTE aims to reduce CO<sub>2</sub> emissions and to optimise the use of energy in neighbourhoods through a cloud platform which hosts energy management systems and decision support services. By integrating local energy sources and storages, both thermal and electrical, and by regulating energy beyond single buildings, the project endeavours to set the roadmap for energy positive neighbourhoods.

with the possibility to not only deliver energy management services but also to accommodate interoperability with other systems other than energy (such as security, transport, traffic or other custom services) which may be of interest for a specific neighbourhood. A substantial validation of the concepts will be conducted at two test sites.



### KEY FACTS

**Start date:** October 2012  
**Duration:** 36 months  
**Total budget (€):** 3.6 million  
**Website:** [www.cooperate-fp7.eu](http://www.cooperate-fp7.eu)  
**Coordinator:** RWTH Aachen University, Germany  
**Partners:** France: Bouygues Energies & Services, EMBIX. Ireland: CIT, Intel Ireland. UK: University of Manchester.

### EXPECTED IMPACT

- 2 demonstrators in total (France and Ireland)
- 10-15% reduction in energy use and 20kg/m<sup>2</sup> CO<sub>2</sub> savings per year (estimated for one test site in France)
- 68,000m<sup>2</sup> of renovated surface area
- Estimated 10 buildings involved and 3,500 end users engaged
- Thousands of people reached by dissemination activity

# E+

## Overview

The construction sector is one of the main energy consumers within Europe, responsible for 40% of energy demand. In addition, the sector is highly polluting with associated CO<sub>2</sub> emissions representing 36% of the total within Europe. In recent years the EU has approved several directives aimed at transforming this sector into a more sustainable activity, especially addressing energy efficiency in buildings by promoting projects in this line.

The E+ project is one of the projects working to achieve this goal. However, rather than only addressing individual buildings the project seeks to improve the environmental impact and energy efficiency at the wider neighbourhood level.

## New systems, technologies and operation models based on ICT for the management of energy positive and proactive neighbourhoods

E+ will develop, implement and validate a new ICT based energy control system at neighbourhood level. This system will consider three operation strategies; looking for real time instantaneous zero energy balance at neighbourhood level for a long term scenario, yearly zero energy balance at neighbourhood level for a mid-term scenario and energy infrastructure optimisation for a short term scenario.

The main objective of E+ is to develop a control system for energy management at neighbourhood level, along with associated new business and operation models. Secondary to this, the project will produce a set of public recommendations for urban planning, addressing refurbishment of both existing and new neighbourhoods.



### KEY FACTS

**Start date:** November 2012  
**Duration:** 42 months  
**Total budget (€):** 5 million  
**Website:** [www.eplusproject.eu](http://www.eplusproject.eu)  
**Coordinator:** CIRCE, Spain  
**Partners:** Belgium: FuturoCité asbl, IDEA, Vue sur Mons SA. Netherlands: DNV KEMA. Romania: Teamnet International. Spain: Acciona Infraestructuras, Agencia Municipal de la Energía de Málaga, IBM S.A., Universidad Pontificia Comillas.

### EXPECTED IMPACT

- 2 demonstrators in total (Belgium and Spain)
- 10% reduction in energy use
- 4 dwellings involved
- €1.8 million investment from project partners
- 20% of project partners are SMEs
- 2 technologies may be taken to market
- 2 patents may be applied for

# NRG4CAST

## Energy forecasting

NRG4Cast is developing real-time management, analytics and forecasting services for energy distribution networks in urban/rural communities. The project will focus on three scenarios (1) predicting energy demand, (2) predicting energy network failures and (3) predicting energy prices. Services will be integrated in a decision support pipeline and will include prediction, network monitoring, anomaly detection, trend detection, planning and optimisation.

### Overview

The main concept of NRG4Cast is to monitor energy behaviour. The system will provide a holistic view of energy consumption from the micro-device level to an aggregate view of energy grid level usage. Users of the system will have different objectives:

- Local Governments may use the system to optimally plan, negotiate and buy energy based on the predicted local demand and energy prices
- A Distribution System operator may use the system to plan contracting with neighbouring distributors to optimise seasonal or peak demand
- Governmental agencies/energy policy makers may use the system to monitor energy consumption and demand forecasting, to help shape energy policies for specific regions
- A local utilities company may use the system to offer flexible pricing based on supply and demand
- A building generating excess power through renewable sources may use

the system to determine the appropriate moment to sell excess energy

- Citizens may use NRG4Cast to plan home usage and charges for electrical vehicles etc. Smart devices or energy home gateways may consult NRG4Cast services before selecting the best energy supplier



### KEY FACTS

**Start date:** December 2012  
**Duration:** 36 months  
**Total budget (€):** 3.7 million  
**Website:** www.nrg4cast.org  
**Coordinator:** Institut Jozef Stefan, Slovenia  
**Partners:** Germany: Forschungsinstitut Fuer Rationalisierung, Greece: Centre For Renewable Energy Sources And Saving, National Technical University Of Athens, Singularlogic Anonymi Etairia Pliroforiakon Sistimaton Kai Efarmogon Pliroforikis. Italy: Consorzio Per Il Sistema Informativo (CSI Piemonte), IREN Rinnovabili srl. Slovenia: Envigence, Okoljska Inteligenca, D.O.O.

### EXPECTED IMPACT

- 4 demonstrators in total (Slovenia, Greece, Italy and Germany)
- Reductions in energy use: 50-60% reduction in public lighting, 5% for large campus, 7-10% for larger city urban area and 5-7% cost saving due to better energy cost prediction models
- 112 buildings involved and 4,500 end users engaged
- More than 50,000 people reached by dissemination activity
- 20-50% estimated return on investment (dependent on the use case)
- €1.4 million investment from project partners
- 12.5% of project partners are SMEs
- 1 integrated pipeline and 8-12 web services may be taken to market
- 5 patents may be applied for

# SmartKYE

## An innovative energy efficiency service platform for smart cities

SmartKYE's aim is to develop an advanced, integrated, management system which enables energy efficiency in neighborhoods from a holistic perspective. The key end-users targeted are the public authorities who can monitor and manage key indicators in neighborhoods with the goal of better energy efficiency and CO<sub>2</sub> reduction.

### Overview

Future Smart Cities will need their districts to be monitored and managed efficiently as part of the smart grid era. However, neighborhoods might significantly differ from each other and infrastructure is expected to be highly heterogeneous e.g. with public lighting systems, urban heating systems, public buildings, commercial centers, electric vehicles, micro-generation, etc.

share data through an open platform among themselves and to external third party applications. In this context there is a need for tools to enable the monitoring of key performance indicators at the district-wide level, being able to assess the behavior of the energy infrastructure deployed in the neighborhoods based on real-time analytics and to take the necessary business decisions.



### KEY FACTS

**Start date:** November 2012  
**Duration:** 30 months  
**Total budget (€):** 3.1 million  
**Website:** www.smartkye.eu  
**Coordinator:** ETRA I+D, Spain  
**Partners:** Germany: University of Duisburg, SAP. Greece: HEDNO, ICCS. Spain: Bdigital, Technoflex.

### EXPECTED IMPACT

- 2 demonstrators in total (Spain and Greece)
- 25% reduction in energy use
- 20% estimated return on investment
- €1.1 million investment from project partners
- 8 technologies may be taken to market
- 3 patents may be applied for

SmartKYE's strategic goal is to develop a system for future smart grid neighborhoods enabling better business decisions to be made based on real-time fine-grained data. Thus the energy management systems deployed in a typical district that are consuming or producing energy, and which nowadays normally count with an isolated IT management solution, will be able to

# CAMPUS21

## Control and automation management of buildings and public spaces for the 21st century

Campus21 will develop, deploy and test an integrated methodology and platform supporting the simultaneous use of existing ICT-subsystems, including energy, building, and security systems. Rather than installing new control systems, Campus21 focuses on improving the integration and energy performance of existing systems in buildings and on campuses in public spaces. Solutions are developed for three distinct demonstration sites in three climate types.

### Overview

Campus21 focuses on the energy efficient operation of public buildings, developing a hardware-software platform and demonstrating cost effective and high performance savings on distinct public demonstration sites. It brings together the expertise of national research centres from Germany (telecommunications), Ireland (IT in AEC, artificial intelligence), Austria (building physics), and Spain (information technology) in addition to the management experience of public authorities. These are grouped with process expertise from multiple industry sectors, such as construction and facilities management, building services systems manufacturers and energy providers. Aside from technical solutions, Campus21 will provide business models and economic solutions to ensure maximum commercial impact for the project.

Due to its cross-sectoral membership, Campus21 spans the entire innovation chain. It contributes to the establishment of world-class infrastructures and the economic recovery plan of the European Union.

The key technological innovations of Campus21 are:

- Integration concepts for energy management systems including related middleware components
- Methodologies for intelligent, optimised control of building services systems
- Algorithms and tools to support load-balancing between renewable micro-generation, storage systems, and energy consuming devices in buildings and public spaces

This is complemented by the development of key business elements, including:

- New business models for integrated energy management and the underpinning novel procurement schemes
  - The development of performance metrics and a holistic evaluation concept for systems' integration
- Campus21 uses existing demonstrators and living laboratories for research and validation of energy and cost savings:
- A large university campus in Cork, Ireland
  - A multi-purpose sports arena in Frankfurt, Germany
  - An indoor sports complex in Valladolid, Spain

### Key Achievements

The integration of methodology and platform to support building performance analysis has resulted in the development of:

- Monitoring concepts and system performance analysis. Vast volumes of building and campus data has been collected, shared, filtered and analysed
- Middleware platform has been designed, developed and installed at 3 demonstration sites in 3 countries
- Control and load balancing components and procedures developed and initial implementation undertaken
- Underpinning procurement and business models for systems integration and building renovation

Specific to each demonstration site in varying countries, initial business and procurement modes have been developed, to be further improved as the project progresses.



### KEY FACTS

**Start date:** September 2011

**Duration:** 36 months

**Total budget (€):** 3.9 million

**Website:** [www.campus21-project.eu](http://www.campus21-project.eu)

**Coordinator:** University College Cork, IRUSE Group, Ireland

**Partners:** Austria: Technical University Vienna. Germany: HSG Zander. Ireland: 4C Group UCC, Electricity Supply Board, Sirus, United Technologies Research Centre. Netherlands: BAM. Spain: CARTIF (Research Centre), Valladolid City Council. UK: NEC.

### EXPECTED IMPACT

- 3 demonstrators in total (Ireland, Germany and Spain)
- 7.5% estimated reduction in energy use and 1Mt per year CO<sub>2</sub> savings
- 10,000m<sup>2</sup> surface area renovated
- 1000 university end users engaged and 50,000 visitors to the swimming pool per annum
- Estimated 300 people reached by dissemination activity
- 20% estimated return on investment
- €1.7 million investment from project partners
- Key training actions: training on standardised data modelling (ifc, BACnet), training on model building for energy simulation and training on procurement and maintenance management (planned)
- 50 people trained
- 10% of project partners are SMEs
- 3-4 technologies may be taken to market



Campus21 demonstration site at University College Cork, Ireland

# IREEN

## ICT for energy efficient neighbourhoods

The IREEN roadmap offers a new insight into the domain of energy efficiency beyond an individual building scale to the broader concept of developing an energy strategy and roadmap for use of technology in energy efficient neighbourhoods. It will offer the foundation for developing an ICT roadmap for European scale innovation and take-up by energy efficient neighbourhoods.

### Overview

IREEN is an FP7 coordination European Commission project. The aim is to present the vision for ICT enabling energy efficiency at a neighbourhood level along with the needs and possibilities for research, technology development and innovation in the near future. The vision is to identify how ICT can contribute to and support improving energy efficiency in both urban and rural neighbourhoods.

IREEN presents an overview of the recognised research, development and innovation needs of ICT for energy efficient neighbourhoods by describing background, state of the art, necessary new capabilities, vision, desired impacts, main barriers and drivers and key stakeholders.

Providing the background context, the project has considered issues of neighbourhood planning, holistic energy efficiency at the neighbourhood level and the needs of rural neighbourhoods. The state of the art vision has been documented alongside this.

The project has developed a structured scoping matrix, outlined as follows: ICT needs for planning and decision making at different levels:

- Neighbourhood level from holistic point of view
- Transportation in the neighbourhood
- Building and infrastructure level focusing on interconnections to the surrounding neighbourhood
- Energy production and storage level

- Energy distribution
- ICT for energy management from the holistic point of view at the neighbourhood level
- Integration technologies at the neighbourhood level

The vision has been developed via a process of:

- Questionnaires from experts focused on scenarios
- Interviews of city representatives in both urban and rural areas across Europe
- Questionnaires and literature search from non-EU countries
- Feedback from the IREEN stakeholder network and expert workshops

### Key Achievements

IREEN seeks to provide an insight in to how this can be delivered using ICT as the supporting mechanism and at the same time acknowledging that the energy efficiency of neighbourhoods is complex due to the broad range of stakeholders and organisations involved. The project roadmap aims to support future research needs and actions over the short, medium and long term, as well as implementation recommendations for each stakeholder group. Full details are can be currently found in four publications, the IREEN Strategy, IREEN Scenarios and a draft IREEN Roadmap.



### KEY FACTS

**Start date:** September 2011  
**Duration:** 27 months  
**Total budget (€):** 1 million  
**Website:** www.ireenproject.eu  
**Coordinator:** Manchester City Council, UK  
**Partners:** Austria: Austrian Institute of Technology. Finland: Teknologian Tutkimuskeskus VTT. France: Centre Scientifique et Technique du Batiment. Italy: D'Appolonia. Netherlands: Green IT Amsterdam. Spain: Acciona, ATOS Spain.

### EXPECTED IMPACT

- IREEN is an FP7 coordination European Commission project focusing on producing strategy. The impact will be measured by the level of influence on EC and city agendas.
- 300 people reached by dissemination activity
- Key training actions: Roadmap for the use of technology in energy efficient neighbourhoods and collaborative workshops on the continuous elaboration and assessment of the innovation strategy and roadmap with experts and stakeholders representing the entire value-chain

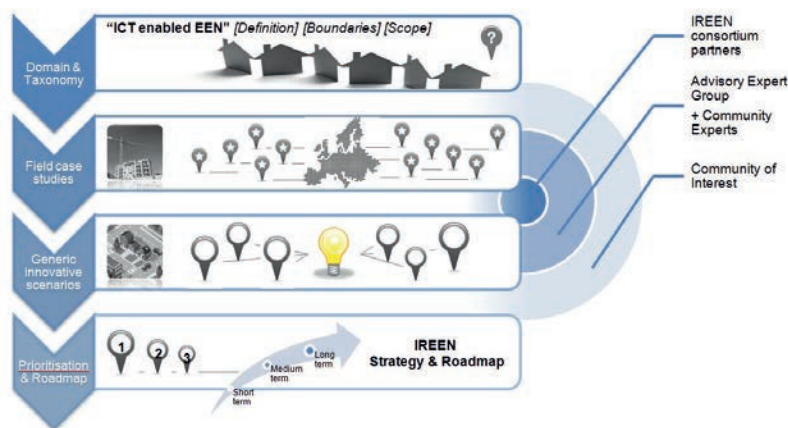

IREEN methodology

# EEPOS

## Overview

Currently, only fragmented solutions for overall energy management and control of neighbourhood energy generation and consumption exist. New business models for district level energy services are still under development. The main idea of EEPOS is to develop technologies and business models that will support energy trading in neighbourhoods. Developed business models will enable a win-win situation between stakeholders of the electricity and heat trading chains. The new EEPOS services will be transparent for both customers as well as providers and allow benefit sharing between them. This will improve the information on which customers base decisions with regards to energy consumption. Raising awareness of energy consumption will reduce users' energy costs and reduce energy peaks

## Energy management and decision support systems for energy positive neighbourhoods

EEPOS is a research and development project aiming to emphasise the concept of energy positive neighbourhoods. The EEPOS consortium develops tools for energy optimisation and end user involvement to improve the management of energy generation and consumption at the neighbourhood level.

in the grid. The developed systems will be validated in two demonstration field tests in Espoo, Finland and Langenfeld, Germany. Furthermore, a complementary simulation based virtual demonstration will be carried out for the municipality of Asparrena in Spain.



### KEY FACTS

**Start date:** October 2012  
**Duration:** 36 months  
**Total budget (€):** 4.1 million  
**Website:** [www.eepos-project.eu](http://www.eepos-project.eu)  
**Coordinator:** Teknologian Tutkimuskeskus VTT, Finland  
**Partners:** Austria: AIT Austrian Institute of Technology GmbH. Finland: Fatman Oy, YIT Kiinteistötekniikka Oy. Germany: Ennovatis GmbH, European Distributed Energy Resources Laboratories e.V. Spain: Ayuntamiento De Asparrena, Solintel M&p SL.

### EXPECTED IMPACT

- 2 demonstrators in total (Finland and Germany)
- 1,060 dwellings involved
- 37.5% of project partners are SMEs
- 2 technologies may be taken to market

# IDEAS

## Overview

There is a need in the EU to reduce CO<sub>2</sub> emissions and to balance energy supply and demand. IDEAS will develop and validate different tools and business models needed for demonstrating the cost effectiveness and incremental implementation of energy positive neighbourhoods:

- The neighbourhood energy management tool to optimise energy production, consumption, storage, trading and intelligent operation of buildings
- The user interfaces will use mixed reality technologies to provide intuitive environments for casual users to improve their energy literacy and energy consumption behaviour
- The decision support urban planning tool will be used to illustrate how the progress towards energy positive neighbourhoods achieved at the demonstration sites can be further scaled up

## Intelligent neighbourhood energy allocation and supervision

IDEAS aims to illustrate how communities, public authorities and utility companies across the EU can be engaged in the development and operation of energy positive neighbourhoods. IDEAS will demonstrate how energy positive neighbourhoods can be cost effectively and incrementally implemented by designing, testing and validating a neighbourhood energy management tool, user interfaces, a decision support urban planning tool and business models.

Appropriate business models for the demonstration cases will be developed and the impact of different utility industry structures on the viability of those business models in different EU countries will be identified.

The tools and business models will be demonstrated in two neighbourhoods: a University campus in France and a newly built residential area in Finland.



### KEY FACTS

**Start date:** November 2012  
**Duration:** 36 months  
**Total budget (€):** 4 million  
**Website:** [www.ideasproject.eu](http://www.ideasproject.eu)  
**Coordinator:** University of Teesside, UK  
**Partners:** Finland: City of Porvoo, Porvoo Energia Oy, VTT. France: CSTB, IBM Montpellier Innovation Lab, Nobatek. Israel: IBM Haifa Research Lab.

### EXPECTED IMPACT

- 2 demonstrators in total (Finland and France)
- 20% overall energy reduction and 15kton of CO<sub>2</sub> savings in Finland
- 42 buildings involved
- Dissemination activity: 1 conference paper and a website
- €1.4 million investment from project partners
- 25% of project partners are SMEs
- 4 technologies may be taken to market
- 4 patents may be applied for

# URB-Grade

## Overview

The platform will become a major tool for city planning and decision making by collecting data from heterogeneous distributed sensors, other open data sources and survey based data. Data is processed using Complex Event Processing (CEP) techniques to generate relevant information which will be available over a common cloud based service platform.

At the building level, assessment of the energetic performance is performed by two possible approaches:

- Theoretical approach: a theoretical analysis based on statistics and surveys
- ESCO approach: intensive measurement, analysis, definition of saving measures, implementation and validation

The ESCO approach due to intensive measurements has the best precondition of producing energy saving results.

## Decision support tool for retrofitting a district, towards the district as a service

The URB-Grade project aims to design, develop and validate a platform for decision support that will allow city authorities and utilities to promote and choose the correct actions. This will enable the upgrading of a district to become more energy efficient and cost effective while also increasing comfort for its citizens in a District as a Service Platform (DaaS Platform) approach.

However, it is not economically feasible at present to perform intensive measurements on a larger scale such as a district, or on a large amount of heterogeneous data.

URB-Grade innovatively combines the benefits of an ESCO approach to minimise extrapolation while maintaining the feasibility of a statistical approach, creating an accurate and fast energy assessment and decision support tool.



### KEY FACTS

**Start date:** October 2012  
**Duration:** 39 months  
**Total budget (€):** 4.2 million  
**Website:** [www.urb-grade.eu](http://www.urb-grade.eu)  
**Coordinator:** Alexandra Institutet A/S, Denmark  
**Partners:** Denmark: Kalundborg Kommune, Seas-Nve Holding AS. Finland: THT Control OY, TTY-Saatio. Spain: Ayuntamiento de Eibar, Fenie Energia SA, Fundación Tekniker, Telvent Global Services SA.

### EXPECTED IMPACT

- 3 demonstrators in total in 2 countries
- 20% reduction in energy use and 62Mt per year CO<sub>2</sub> savings
- 27,000 people reached by dissemination activity
- €4 million investment from project partners
- 22.2% of project partners are SMEs

# ICT4E2B Forum

## European stakeholders' forum to explore further research and integration of ICT systems for energy efficiency in buildings

The ICT4E2B Forum project brings together all relevant stakeholders involved in ICT systems and solutions for energy efficiency in buildings. The project community identified and reviewed the needs of ICT and construction in terms of research and system integration. ICT4E2B's Forum Technology roadmap will ease the implementation of innovative solutions and will facilitate the sharing of best practice across Europe.

### Overview

Buildings in Europe are responsible for 40% of energy consumption and 36% of carbon emissions. Therefore, improving the energy performance of buildings is key in achieving EU climate and energy objectives.

The strengthening of research investments in Information and Communication Technologies (ICTs) in relation to the building sector plays an essential role. Enhanced ICT systems will support the need to develop innovative business models and services that can provide continuous and precise information to decision makers, industries and policy makers. Within this framework the ICT4E2B Forum project intended to promote a better understanding of the use of ICT to support informed decision making in the delivery and use of energy efficient buildings. The project is aimed to encourage a closer dialogue and a more active cooperation between researchers, end-users, practitioners, building owners, technology suppliers, and software engineers.

The work carried out builds on the research results previously carried out in the REEB project. The intention was to update the existing REEB roadmap, consisting of the Vision

Strategic Research Agenda (SRA) and the Implementation Activity Plan. This previous work provided a solid ground for the extended research roadmap developed in ICT4E2B Forum, which defines objectives for future research topics in the short, mid and long-term. A significant group of various stakeholders was involved in the roadmap development through workshops, community building activities and web questionnaires. They participated in activities from the beginning, and thus discussed profoundly and validated the priorities addressed in the roadmap.

### Key Achievements

The key achievement of the project is the creation of a dynamic community representing ICT, construction and energy players as well as public stakeholders and authorities, sharing and validating future needs and able to influence future development routes for research and innovation in this field. Five main research areas of ICT applied to the energy efficiency of buildings were identified. For each area, detailed roadmaps for the short, medium and long term were developed. These results were summarised in a book freely available on the project website ([www.ict4e2b.eu](http://www.ict4e2b.eu)).



#### KEY FACTS

**Start date:** September 2010  
**Duration:** 26 months  
**Total budget (€):** 1.4 million  
**Website:** [www.ict4e2b.eu](http://www.ict4e2b.eu)  
**Coordinator:** D'Appolonia S.p.A, Italy  
**Partners:** Finland: TEKNOLOGIAN TUTKIMUSKESKUS VTT. Germany: SAP. Poland: Mostostal Warszawa. Spain: Atos Research. Sweden: Schneider Electric.

#### EXPECTED IMPACT

- 16,430 total people reached by dissemination activity (visits on the project website, project's online forum, LinkedIn group and attendees at workshops, conferences and events, including the final event at the European Parliament in Brussels with 120 attendees)
- €500,000 investment from project partners

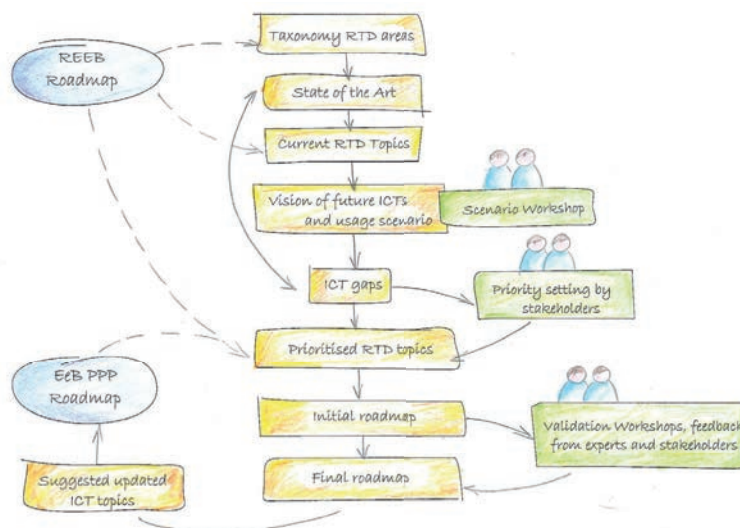

The development process of the ICT4E2B Forum roadmap focused on ICT applied to energy efficient buildings

# REViSITE

## Roadmap enabling vision and strategy in ICT-enabled energy efficiency

Energy efficiency is paramount in ensuring the energy security and sustainability of Europe. While the enabling role of ICT is clear, understanding which technologies are best positioned to deliver meaningful impact is less so. REViSITE is a coordinated action, to promote cross-sectoral (between grids, manufacturing, buildings, and lighting) synergies to positively impact on sustainability goals and to identify research priorities.

### Overview

Often industry bodies act as custodians of the Research and Technology Development (RTD) strategy for their respective sectors. The grid, buildings, manufacturing, and lighting sectors are no different, with a number of European Technology Platforms (ETPs), such as SMARTGRIDS, ECTP, ARTEMIS, MANUFUTURE and PHOTONICS21 representing their respective RTD interests. Aside from ETPs, many other initiatives lobbying to shape future research also exist. So, given the existence of such sectoral initiatives, it was felt there was a justifiable need for a cross-sectoral effort in identifying complementary areas for ICT4EE research trajectories.

In order to capitalise on its potential benefits in the domain of ICT4EE, the objectives of REViSITE are as listed below:

- A multidisciplinary community to promote cross-sectoral ICT4EE i.e. the project looked to leverage the heuristic and domain expertise of different stakeholders
- A common means of assessing the impact of ICTs on energy efficiency i.e. a generic means of identifying and assessing across the four target sectors

- A cross-sectoral ICT4EE Roadmap including - the Vision, the Strategic Research Agenda (SRA) and its associated Implementation Action Plan (IAP) i.e. where should ICT4EE research focus and who should do what in supporting that research effort
- A set of recommendations for standards to address interoperability barriers to ICT4EE

### Key Achievements

The main results of REViSITE are:

- The REViSITE cross-sectoral community: more than 100 experts across the four sectors
- The SMARTT Taxonomy: A common taxonomy which comprised six high-level categories and 23 sub-categories covering the scope of the ICT4EE domain
- Strategic Research Agenda: essentially consisting of six 'roadmap' tables aligned to the SMARTT categories and sub-categories
- Implementation Action Plan: focused on identifying potential call themes/text and on stakeholder-specific actions
- Proposed Recommendations for Standards: to overcome interoperability barriers, centred on specific actions of relevance to Standards Organisations



### KEY FACTS

**Start date:** February 2010

**Duration:** 29 months

**Total budget (€):** 1.8 million

**Website:** [www.revisite.eu](http://www.revisite.eu)

**Coordinator:** Loughborough University, UK

**Partners:** - Finland: VTT Technical Research Centre. France: Centre Scientifique & Technique du Bâtiment. Germany: The Fraunhofer Institute for Production Systems and Design Technology IPK. Ireland: Intel Labs Europe. Italy: Innova SpA. Netherlands: KEMA consulting.

### EXPECTED IMPACT

- The main impact has been to identify, consolidate and promote the common Research and Technical Development priorities for ICT4EE in several (initially 4) industry sectors.
- The developed generic means of assessing the potential impact of ICT on energy efficiency will lead to quantified assessment of energy usage and flag areas for improvement
- Identification of a strategic research agenda that is focused on critical cross-sectoral research trajectories will help the transfer of successful energy efficiency learning from one sector to another
- A common vision for multidisciplinary ICT-enabled energy efficiency will bring together all influential and active communities to work together
- The generated recommendations to regulation bodies for overcoming 'barriers to interoperability' were identified within the project as a paramount issue for realising the potential offered by ICT

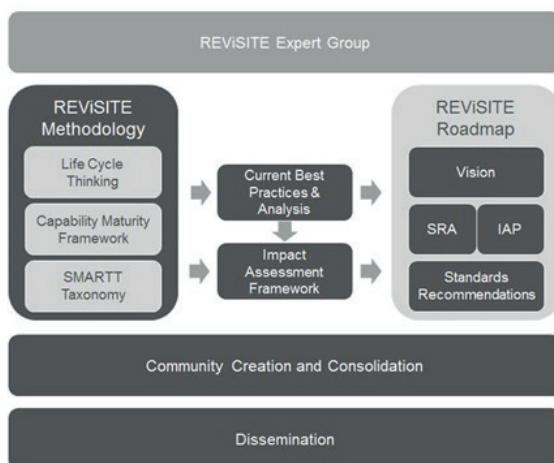

The REViSITE approach



For more information on E2BA contact:

**Luc Bourdeau**

ECTP-E2BA Secretary General  
REH, rue d'Arlon 63-67  
B-1040 Brussels  
secretariat@e2b-ei.eu  
www.e2b-ei.eu

Editor: Claire Hughes | Arup | London  
Design: Megaluna, Brussels

